

Power Unit: Eight Channel

MP-06-08

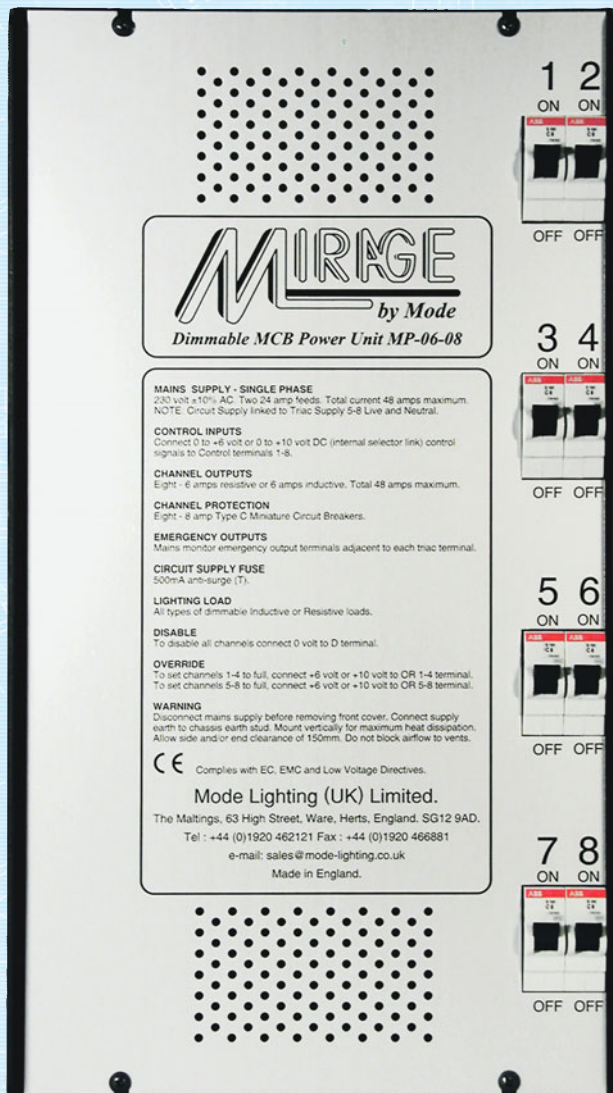

- ❶ EIGHT DIMMABLE CHANNELS of 6 Amps resistive or inductive loads.
- ❷ CIRCUIT PROTECTION individual 8 Amp Type C MCB for each channel.
- ❸ EMERGENCY OUTPUTS fixed live MCB protected outputs for maintained emergency supplies.
- ❹ LED CHANNEL MONITOR to indicate the operation of each output.
- ❺ CONTROL INPUT suitable for use with 0-6 Volt or 0-10 Volt controllers.
- ❻ SUPPLY INPUT 230/240 Volt. 50-60Hz. 2 x 24 Amp maximum (100 - 125 Volt option available).
- ❼ INTERNAL TEST SWITCH (2) to enable all eight channels to be locally tested to full on.
- ❽ TRIAC with screw fixings can be removed for servicing.
- ❾ EXTERNAL SUPPLY low voltage D.C. for use with remote dimmers and ancillary equipment.
- ❿ CONDUIT CABLE ENTRIES (eight) 25mm diameter suitable for use with conduits and trunking.
- ⓫ COMPLIES with EC EMC and Low Voltage Directives (CE).
- ⓬ BLACK ALUMINIUM case with silver anodised front panel.
- ⓭ MODE products are guaranteed for two years.



TECHNICAL DATA

	MP-06-08
Mains Supply	230/240 Volt, 50-60Hz. 2 x 24 Amp maximum.
Control Fuse	500 mA anti-surge (T).
Earth	This product must be earthed.
Channel Outputs	Eight channels of 6 Amps for resistive or inductive loads.
Load MCBs	Individual Miniature Circuit Breaker (MCB) 8 amp, Type C.
Control Input	0-6 or 0-10 Volt D.C. analogue control (selectable).
Override	Low voltage override using latching device.

	MP-06-08
Standards	EMC Emissions EN55015, EMC Immunity EN61547, Harmonics EN61000-3-2, Voltage fluctuation EN61000-3-3, Safety EN60439-1 and EN60950
Conduit Entries	Eight of 25 mm diameter.
Dimensions	470 mm x 262 mm x 75 mm.
Fixing Centres	432 mm x 138 mm.
Weight	4.7 kgs.
Packed Size	485 mm x 280 mm x 90 mm.
Packed Weight	5 kgs.

DESCRIPTION

The Mirage MP-06-08 is a wall mounting, eight channel, Dimmable Power Unit designed for the reliable, leading edge, mains dimming of resistive or inductive lighting loads. Each of the eight circuits is rated at 6 Amps resistive or inductive load and is protected by a Type C Miniature Circuit Breaker (MCB). The control input can be either 0-6 Volt or 0-10 Volt signals from the Mode control systems. The outputs can also be overridden by a latching contact input. The MP-06-08 is mounted in a black aluminum case with a natural anodised silver front panel. All Mode products are guaranteed for a two year period.

MP-06-08 INTERNAL DETAILS

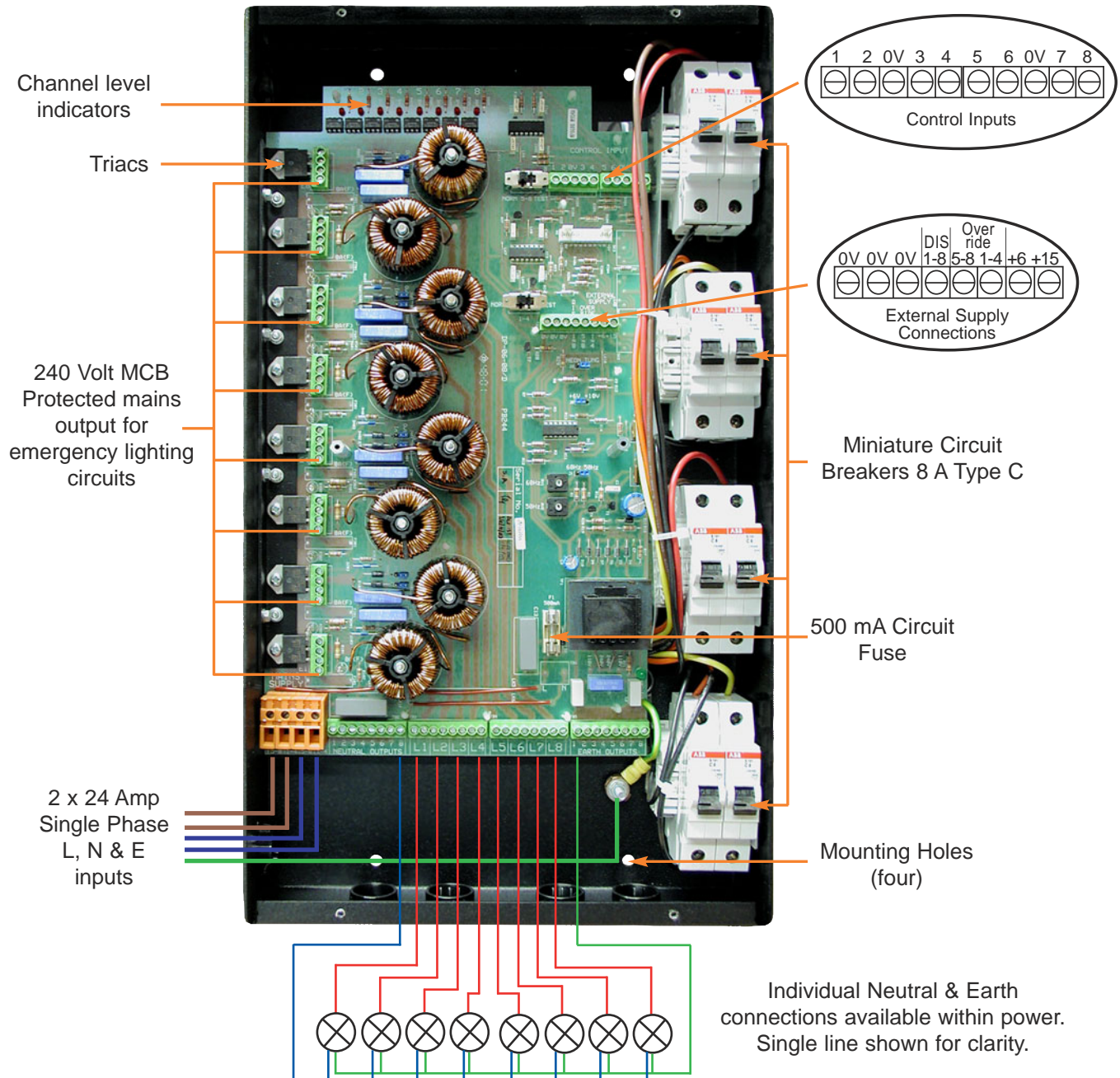

COMPANY SUMMARY

Mode was established in 1970 as an Original Equipment Manufacturer in Hertfordshire, England. Mode designs and manufactures electronic products principally for the lighting industry, initially supplying the discotheque market and more recently expanding into the architectural and cruise ship markets. Mode is a subsidiary of a privately owned Holding Company and has four associated electronic companies who together trade as "The Mode Group".