



Frequently Asked Questions / Troubleshooting

Channels flashing in sequence

Pack address not set using the DIP switch on the front of the processor module

Plate LEDs flashing red-green-blue

M-Bus wiring, termination or data error. Follow instructions on page xxxx.

Plate LEDs flashing all red simultaneously

Plate address not set. See page xxxx.

How Do I Switch Lights On?

If you have plates connected, your bus is correctly wired, and your pack is using the factory-default settings then press the top-left button to bring all channels to 100% over 3 seconds.

If you do not want to use the plates, or your bus is not correctly wired, the channels on each dimming card may be

Channels Do Not Dim (3A/chan pack)

The 3A/chan packs adopt a switching behaviour by default to prevent damage should non-dimmable loads be connected before the commissioning. Use the PC software to configure the pack.

Channels Do Not Dim (All Pack Types)

Check whether the dimming-cards are on test mode. In test mode all channels on the dimming card are kept at 100% all the time. On 3A/chan cards this is the bottom DIP switch (number 8) which you should ensure is in the left position to take the card out of test mode. On 6A and 10A cards check the test mode switch (see picture on page xxxx), which should be in the "up" position to leave test mode.

The 1-10v Configurable Outputs Do Not Control My Fluorescent Ballasts In Test Mode

When the pack is using the factory-default settings the configurable I/O terminals are not configured, and will therefore not output a control voltage. To set up control on the configurable I/O terminals use the PC software. For more information see the Evolution Software Manual.

DMX Data Is Not Output, or Insufficient DMX Channels Are Being Generated

Check the polarity of your DMX+ and DMX- connections. Switch on the DMX generator, and set the number of channels to be generated. See BIOS settings on page xxxx.

Fluorescent Ballasts Do Not Respond Correctly

Check the ballast type that has been installed to see if they require 1-10v control or DSI data. If you are using a configurable terminal on the Evo pack then the type of data generated can be swapped using the Evolution software. The Evo pack is not currently compatible with DALI ballasts.

Operation Of The System Appears Slow

Check that diagnostic commands have been switched off (type EVOD0SET inHyperTerminal – see page xxxx). Switch of unnecessary DMX channel generation (see page xxxx). If problems persist, please contact Mode Lighting (UK) Ltd tech support department with a copy of your .evo file for analysis.

Which Version Of Firmware Is In My Pack?

Connect a PC to your pack, and run HyperTerminal (see page xxxx). Type the command EVOSYS and examine the output for details of the firmware you are running. For the latest version visit www.evolutioncontrols.com or contact Mode Lighting (UK) Ltd technical support dept.

What are the M-Bus Connections A, B, C and D?

All you need to do is make sure that A on all bus devices is daisy-chained to A on all other bus devices, and likewise for B, C and D as per the guidelines on page xxxx. The Evolution M-Bus uses our own proprietary message format. A and B carry the 24v power and C and D carry the data. Therefore A and B should be of suitable cross-sectional area for the load being driven, and C and D should be a twisted or shielded pair.

The LCD Plates Display "Sorry, no data has been found for this plate..." on The Screen

This is normal behaviour when the system is in factory-default settings. Until a file is uploaded into the packs, then no configuration data for the plates is available. If you have uploaded a configuration then make sure that the file contains data for an LCD plate with the address shown on the screen.

The Power and Processor Unit Seems Unusually Noisy When Dimming

Check that you have not connected a non-dimmable load, such as a fluorescent ballast, to a dimmed mains output of the pack. This can result in damage to the pack. Check whether the suppression capacitors are engaged (see page xxxx for more information).

Mode Lighting (UK) Ltd

The Maltings, 63 High Street, Ware, Hertfordshire, SG12 9AD, ENGLAND. Telephone:+44 (0)1920 462121 Facsimile:+44 (0)1920 466881
e-mail:sales@modelighting.com website:www.evolutioncontrols.com



Evolution Power Units - Overview

The Evolution power and processor units combine high power, quality dimming circuitry with intelligent control capabilities for multiple function use. MCB circuit protection is fitted as standard with single or three phase input options also standard. DIN rail terminals are used throughout for all mains input and output connections (3A models use PCB mounting terminals for space saving) to aid simple, trusted installation. The high quality design and engineering within Mode products draw on over 30 years experience in manufacturing dimming systems and understanding the requirements of designers and installers alike to create powerful control systems that are both reliable and cost effective. The manual details the full mechanical, electrical and control installation for the range of Evolution power and processor units.

Index

	Page
Evolution Power Units – Overview	1
Contents	1
Installation Checklist	3
Electrical Specification	4
Mechanical Specification	5
CE EMC / LVD Requirements Compliance	5
Installation Procedure	6
Initial Operation (Factory Default Behaviour)	6
Before Installation	6
Mechanical Installation	6
Installation-Mains Cable Trunking/Conduit	7
Electrical Installation - Mains Input Wiring	8
Electrical Installation - Mains Output Wiring	8
Electrical Installation - Emergency Lighting/Wiring	8
Load Types	9
M-Bus Wiring	11
M-Bus Termination	11
M-Bus Cable Requirements	11
Using Cat 5 Cable	11
Testing the M-Bus Wiring	11
Verifying Correct Bus Operation At Power-Up	12
Diagnostics – Power Supply LEDs	12
None Indicators - Mains	12
Green LED – M-Bus Power	12
Amber LED - Mains	12
Red LEDs On Digital Board – Low Voltage Power	12
Amber LEDs On Digital Board	12
Appendix - Wiring Examples	13
M-Bus Example	13
1-10V Output using Outputs A1-A18	13
DMX Input Example	14
DMX OUTPUT EXAMPLE	16
DALI Output	16
Onboard Relay Contractors	17
Configurable Input/Output Options	18



1-10V Inputs	18
0-10V Output using Configurable Terminals. (Fluorescent Ballast as an example)	18
DSI Output using Configurable Terminals	19
Plate Contact Closure Example	19
Connection to a CRESTRON System	20
Connection to an AV System or Computer via RS232	20
<diagram required>Factory Reset Procedure	21
Factory Reset Procedure	21
Setting Up a PC For Diagnostics and Testing Using HyperTerminal	22
Diagnosis of M-Bus Problems Using HyperTerminal 'N' and 'B'	23
Changing BIOS Settings	24
Diagnostic Commands	24
APPENDIX A:UPGRADING POWER AND PROCESSOR PACK FIRMWARE	26
Appendix - Device Address DIP-Switch Settings	28
Appendix - Port Wiring Diagrams	30
Programming M-Bus Port	30
RS232 Port	30
Control Plate Installation	30
Fitting The Fascia Plate	31
How To Remove A Fascia Plate	32
Control Plate Diagnostics	32
Plate LEDs flashing Red-Green-Blue in Sequence	32
Plate LEDs flashing Red Pairs in Sequence	32
Plate LEDs flashing All Red LEDs Simultaneously Three Times In Quick Succession	32
Plate LEDs are Flashing 1-2-3-4-5-6-7-8-9-0 In Sequence	32
Checking a Plate Address and/or "Proof of Life"	32
How To Set The System Clock Using An LCD Plate	33
Glossary of Terms	33
Frequently Asked Questions / Troubleshooting	34
Channels flashing in sequence	34
Plate LEDs flashing red-green-blue	34
Plate LEDs flashing all red simultaneously	34
How Do I Switch Lights On?	34
Channels Do Not Dim (3A/chan pack)	34
Channels Do Not Dim (All Pack Types)	34
The 1-10v Configurable Outputs Do Not Control My Fluorescent Ballasts In Test Mode	34
DMX Data Is Not Output, or Insufficient DMX Channels Are Being Generated	34
Fluorescent Ballasts Do Not Respond Correctly	34
Operation Of The System Appears Slow	34
Which Version Of Firmware Is In My Pack?	34
What are the M-Bus Connections A, B, C and D?	34
The LCD Plates Display "Sorry, no data has been found for this plate..." on The Screen	34
The Power and Processor Unit Seems Unusually Noisy When Dimming	34

Document version: 1.00, July 2005

Authors: James King, Sam Woodward
 Graphic Design: Lance Langley
 Wiring Diagrams: James Taylor
 Editor: Andrew Morris



Checklist

Item	Page	Check
Evolution Power and Processor Unit ("pack") has been completely removed from all packaging		
Packs have been securely mounted to a wall, the correct way up and away from moisture hazards		
Packs have sufficient clearance around them, and sufficient airflow		
Trunking / conduit mounting correctly installed		
Mains input is protected with a suitable breaker at the distribution board		
All three live input terminals, neutral, and earth are properly connected. Cables are secure – screws are tightened NB Note new colours for mains cables: are these correctly wired to the pack		
Loads have been connected to the correct mains output terminals and loads are of appropriate size for the dimmer current-rating being used		
Permanent mains feeds for emergency light fitting charging circuits are correctly connected to the red "Emergency" terminals		
There are no mains connections to the low-voltage terminals on the Digital Board (with the possible exception of the mains-rated relay terminals at the bottom of the board)		
6A/10A-per-channel packs only: All non-dimmable "Switched" loads, such as fluorescent ballasts, have been set to switched-only operation using the jumper links on the dimming cards		
Low voltage wiring has been completed according to the wiring diagrams in this manual Analogue outputs – wired between An and 0v Configurable analogue inputs – wired between Cn and 0v Configurable analogue outputs – wired between Cn and 0v Configurable digital inputs – wired between Cn and 5v Configurable DSI outputs – wired between Cn and 0v DMX In – wired to DMX In +, DMX-IN - and 0v terminals DMX Out – wired to DMX Out +, DMX Out - and 0v terminals		
M-Bus wiring is A-A, B-B, C-C, D-D in a daisy-chain between all bus devices		
Ensure C and D are twisted/shielded pair		
M-Bus total length is less than 1000m (if a longer bus is required please contact Mode Lighting (UK) Ltd. for advice)		
M-Bus is terminated at the two open ends: DIP-switch 10 on the last plate in the chain, if applicable DIP-switch 9 on the last pack in the chain, if applicable		
All bus devices (packs, plates, relay units etc.) have the correct address set using their DIP-switches EVO-INT-232 devices providing extra RS232 ports have the correct address set using the rotary-switch. Check that plate addresses have not been changed by the cable pressing on the DIP switch		
All plates are fitted with flat-headed screws (not domed screws)		
Plate buttons are free to move, and are not jammed underneath the fascia		
Test mode switches are "Off" for normal operation		



Electrical Specification

Item	EVO-03-18 18 channels 3A per chan	EVO-03-36 36 channels 3A per chan	EVO-06-09 9 channels 6A per chan	EVO-06-18 18 channels 6A per chan	EVO-10-06 6 channels 10A per chan	EVO-10-12 12 channels 10A per chan
Power Supply Voltage In	230V AC Nominal (207V – 253V), 50Hz Single Phase (three feeds), Neutral and Earth or Three Phase, Neutral and Earth star-configuration or Three Phase Delta available to special order					
Power Supply Current	60A total i.e. 20A per phase	120A total i.e. 40A per phase	60A	120A	60A	120A
Dimming Outputs	Hard fired leading edge triac triggering 32-bit digital dimming Compatible with mains halogen, Dimmable LV transformers, Dimmable Neon/Argon converters					
Maximum Load Per Channel (Resistive)	3A 750W		6.6A 1500W		10A 2400W	
Maximum Load Per Channel (inductive)	3A 750W		6A 1500W		9A 2400W	
Maximum Load Per Channel (Switched)	Software configurable 750W		Jumper-link or software configurable 1500 W		Jumper-link or software configurable 2400W	
Minimum Load	40W per channel (200W for fluorescent ballasts, with channel set to switched output)					
Output Protection Mains Voltage Type C Breaker	8A breaker shared between 2 channels		Individual 8A breaker per channel		Individual 10A breaker per channel	
Output Protection Low Voltage	2A HRC 20mm fuses 1 fuse per phase					
Low Voltage Dimming Outputs	18 x 0-10v Analogue Outputs Up to 250mA each, total 3A					
Low Voltage Configurable Control Inputs / Outputs	16 channels configurable as any combination of: 0-10v Output 0-10v Input "Digital" contact-closure input (see wiring instructions) DSI output (250mA per channel, max 3A total)					
DMX Output	USITT DMX512 (1990): 256 Channels Each pack generates an independent DMX universe					
DMX Input RS232	512 channels, assignable to any outputs or scenes 5-wire interface with RTS/CTS handshaking 9600 Baud, 8 data bits, 1 stop bit, no parity Connection via 9 pin D Connector (female on pack) Additional configurable RS232 interfaces may be connected to the bus					
M-Bus	Evolution proprietary 4-wire M-Bus. Daisy-chain topology Max distance between network extenders: 1000m Each Pack can supply up to 2A to the bus devices. Maximum of 62 packs per network (networks may be joined) Maximum of 512 LCD plates (100mA each, max 20 per pack) per network* Maximum of 512 Single-Gang Button Plates (40mA each, max 50-100 per pack) per network* * Subject to a maximum total bus load of 2A per pack					
DALI	Reserved for future expansion. Please refer to Mode for further information					
Change-over relay contacts	2 x SPCO volt-free relay contacts with N/O, N/C and Common terminals Max 3A per relay resistive or inductive					
DC Outputs	24v, max 2A total, including bus load (see M-Bus, above) 15v, max 1A 5v, max 0.5A					
"Alarm" input	Connect a volt-free contact-closure between the 15v terminal and the ALM terminal to switch all selected alarm circuits to 100%.					



Mechanical specification

Item	EVO-03-18 EVO-06-09 EVO-10-06	EVO-03-36 EVO-06-12 EVO-10-12
Weight (Packed)	11.3kg	12.3kg
Weight (Unpacked)	9.5kg	10.5kg
Height (Unpacked)	534mm	534mm
Width (Unpacked)	322mm	322mm
Depth (Unpacked)	160mm	160mm
Height (Packed)	600mm	600mm
Width (Packed)	400mm	600mm
Depth (Packed)	240mm	240mm
Fixing Centres Vertical NB Allow 300mm top clearance	452mm	452mm
Fixing Centres Horizontal	302mm	302mm
Operating Temperature	0°C to 40°C	
Maximum Case Temperature	+90°C	
Maximum Cable Size Phase / Live Input	4-25mm ² solid 4-16mm ² stranded	
Maximum Cable Size Neutral Input	10-50mm ² solid 10-36mm ² stranded	
Maximum Cable Size Earth Connection	10-50mm ² solid 10-35mm ² stranded	

NB The unit must be mounted vertically, with the mains wiring at the bottom

CE EMC / LVD Requirements Compliance

EMC Emmissions	BSEN 55014
EMC Immunity	BSEN 61547
Harmonics	BSEN 61000-3-2
Safety	BSEN 60439-1 / BSEN 60950
Isolation	BSEN 60065

Installation Procedure



Installation Procedure

1. Attach Power and Processor Unit to a suitable wall and install mains wiring
2. Connect control plates and Evolution network devices to the M-Bus terminals.
3. Set device addresses on all devices using DIP switches.
4. Set Terminating resistors at ends of Bus.
5. Power up system.

You should ideally power up pack 1 before, or at the same time as, any other packs on the network. However if you are not able to do this you will need to wait for up to a minute for the packs to become operational.

Before Installation

Read instructions fully prior to unpacking unit and retain for future reference. Further copies can be downloaded from the website www.evolutioncontrols.com

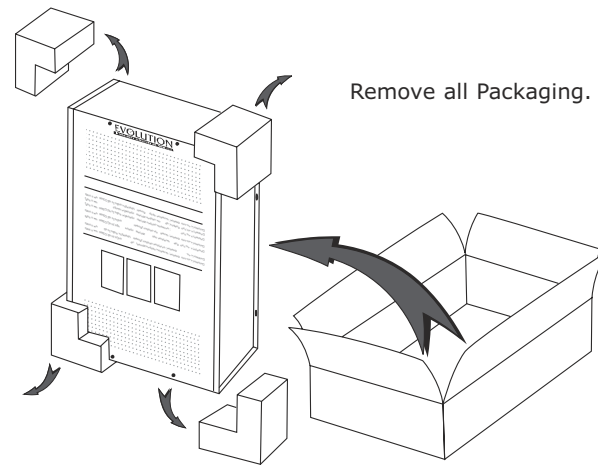
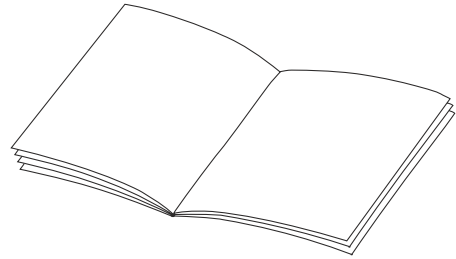

Initial Operation (Factory Default Behaviour)

When first installed the behaviour of a system is the same regardless of the number of loads or control plates connected:

All plates will control all mains power channels and set them at preset levels, 90-70-50-30-0. The top-left button on the plate gives 100%, whilst the bottom left button fades to all off. The RS232/DMX configurable I/O's will have no effect. (see page 21)

If a pack has an address other than 1, and there is no pack with address 1 connected to it then there will be a short delay (more than 20 seconds) before the pack will operate, whilst it scans the network looking for pack 1. When it finds that there is no pack 1 it takes over operation of the network.

Mechanical Installation

There are two physical sizes of the Evolution Power and Processor Unit (hereafter referred to as the "pack"), the smaller pack can handle a maximum load of 60A, whilst the larger pack can handle a maximum load of 120A. There are three different power-per-channel configurations available in each size: 3A, 6A and 10A. A single pack will only contain dimmer modules of one current rating (i.e. there is no mixture of the 3A, 6A and 10A modules within one pack). Different types of pack may be networked together.

Mark out space for unit on wall allowing for clearances top (300mm) and side (40mm). Noting the different dimensions for the 60 Amp and 120 Amp units.

Units must always be mounted vertically with Base entry/exit for all mains connections.

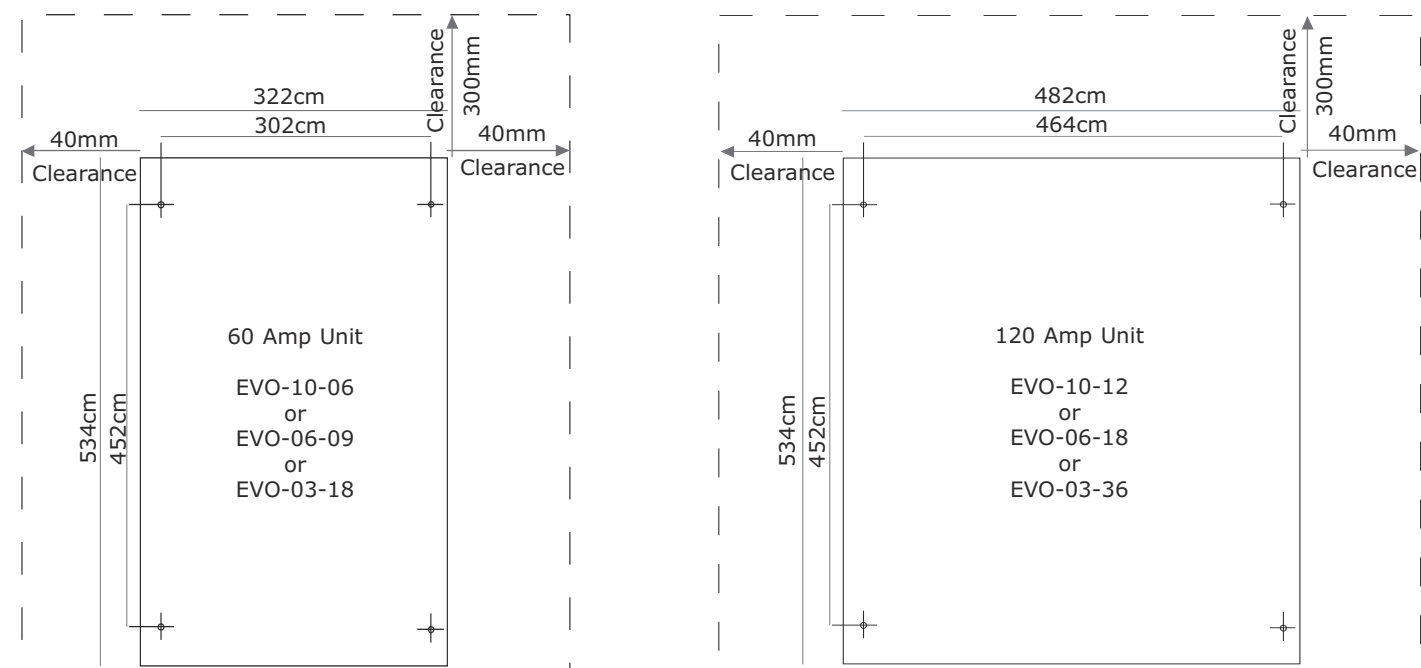

Installation-Mains Cable Trunking/Conduit

Mark and cut trunking to suit cable entry option.

Option 1 Knockouts in base plate to suit 32mm couplers.

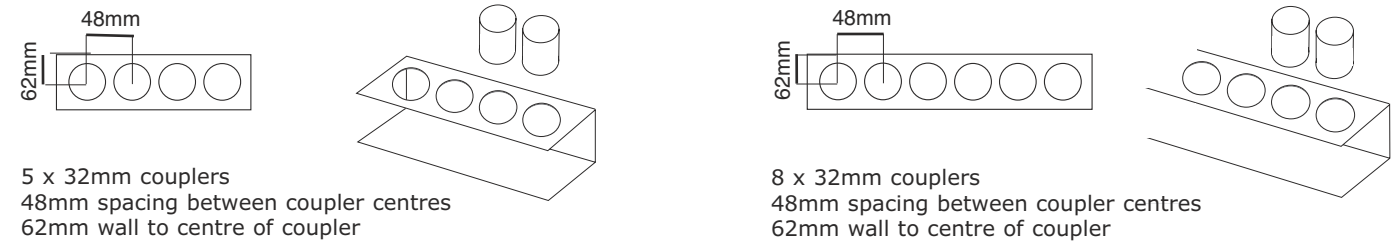

Option 2 Remove base plate + cut hole in trunking

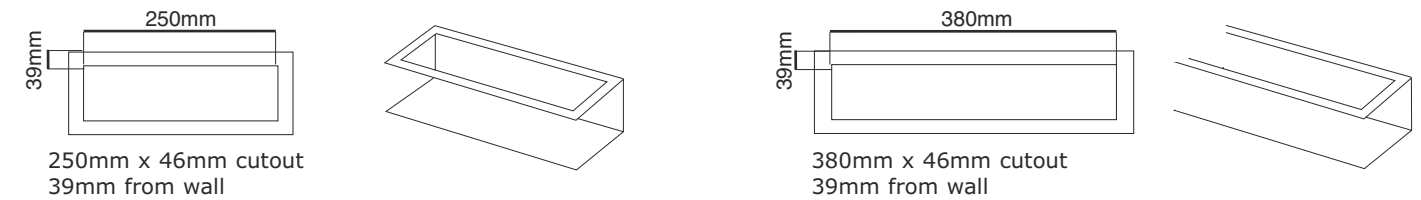

Do not drill any additional holes onto the Evolution Power and Processor Pack. Do not allow any swarf to enter the pack.

Wall Mounting

Fit trunking and unit to wall using suitable fixings.

Inside The Power and Processor Unit

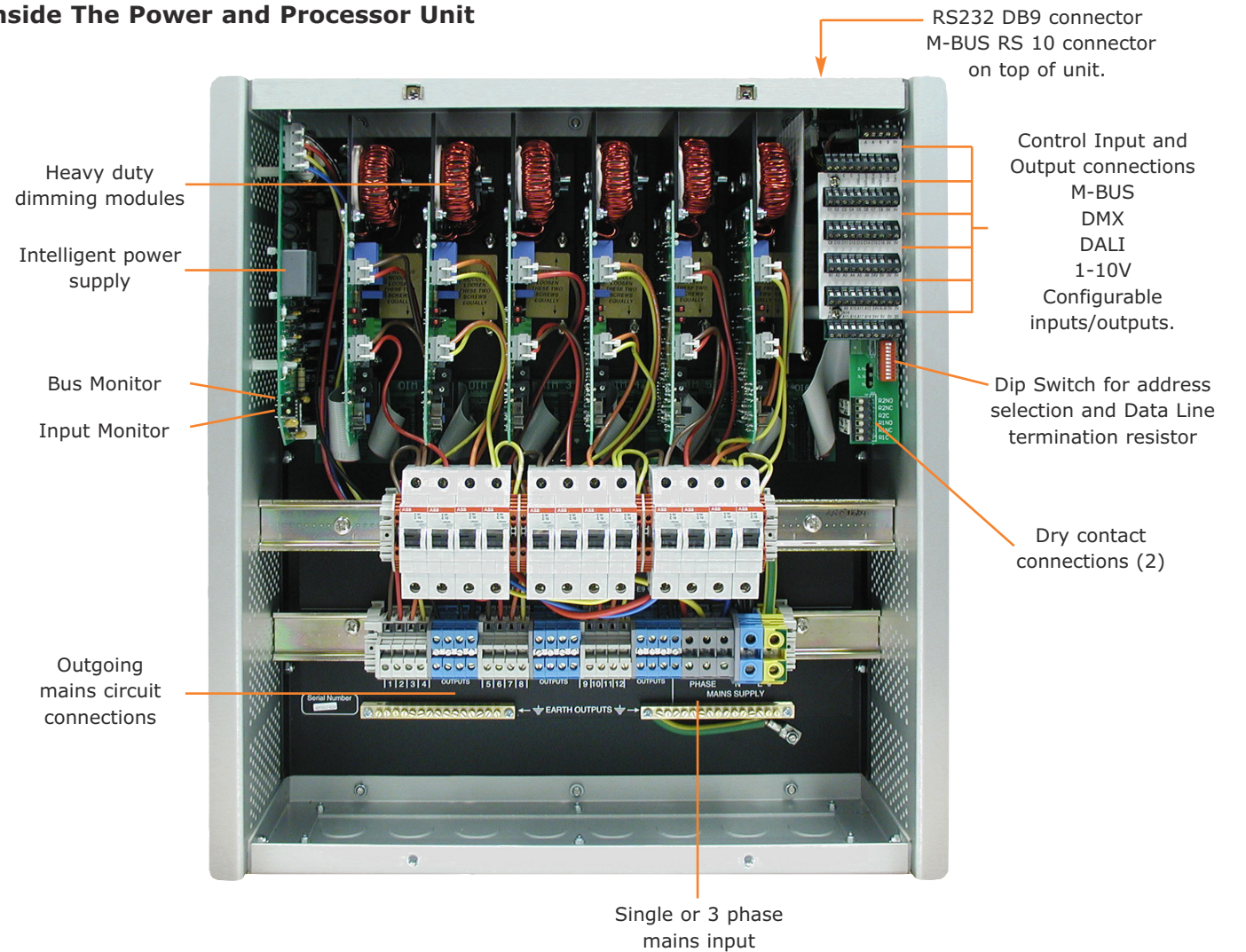

Electrical Installation



Electrical Installation - Mains Input Wiring



IMPORTANT:- Unit must be installed by a suitably qualified Electrician. All wiring must be carried out to National Wiring Regulations and take into account any other Regulations that may be applicable or enforced.

Install power input cabling noting the recommended conductor sizes and in accordance with the calculated loads. The Evolution Power Units accept 3 live inputs with a neutral and common earth connection. The live inputs may be single or three phase format, any combination of phases is acceptable. (Delta Input wiring is available to special order. Please contact Mode Lighting (UK) Ltd for details). Power must be fed from a suitably rated isolator/protection device.

Current Rating and Cable Sizes

	EVO-03-18 EVO-10-06 EVO-06-09	EVO-03-36 EVO-10-12 EVO-06-18	Maximum Cable Size
Phase / Live Input	20 A max	40 A max	4-25mm ² solid 4-16mm ² stranded
Neutral Input	60 A max	120 A max	10-50mm ² solid 10-35mm ² stranded
Earth Input	60 A max	120 A max	10-50mm ² solid 10-35mm ² stranded

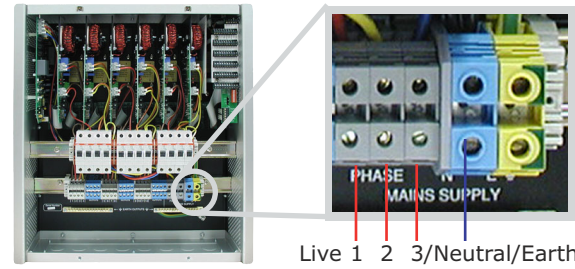

Electrical Installation - Mains Output Wiring

The mains outputs from the Evolution Units are located at the bottom of the unit. Live and Neutral connections are by DIN rail mounted terminals with separate earth bars for the earth connections. Cables must be rated in accordance with the calculated loadings and lengths and conform to National Wiring Regulations and other Regulations that may be applicable or enforced.

6A +10A models (EVO-10-06, EVO-06-09, EVO-10-12, EVO-06-18)

Terminals will accept cables 0-6mm² stranded and 0-10mm² solid.

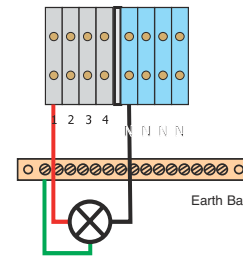
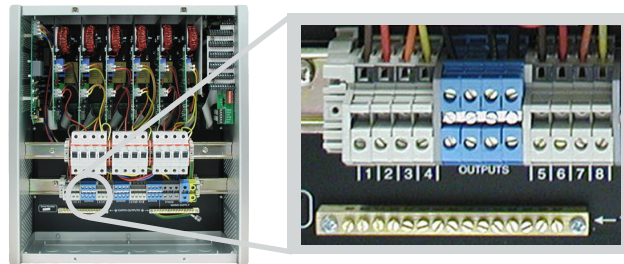

Example connections - lighting loads

3A models (EVO-03-18, EVO-03-36)

Terminals will accept cables 0-6mm² stranded and 0-10mm² solid.

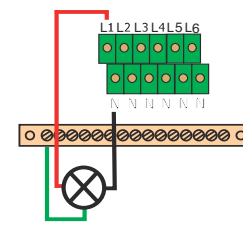

Electrical Installation - Emergency Lighting/Wiring

Each Evolution Power Unit has six terminals fitted for permanent feeds for emergency lighting monitoring. These terminals are connected to the outer breakers for each phase.

Circuits with emergency lighting should be connected to these circuits. The permanent/charging live feed should be connected to the red emergency terminal and the normal switch line connected to the standard outgoing circuit terminal. If the MCB protecting the dimmed circuit trips the live feed to the emergency terminal will be removed.

6A +10A models

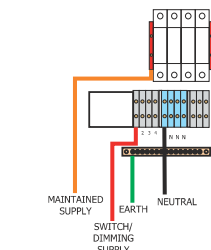
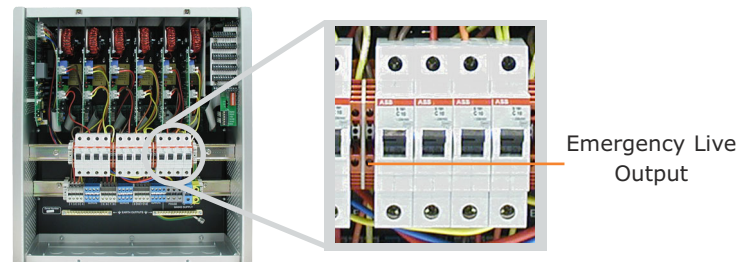

3A models

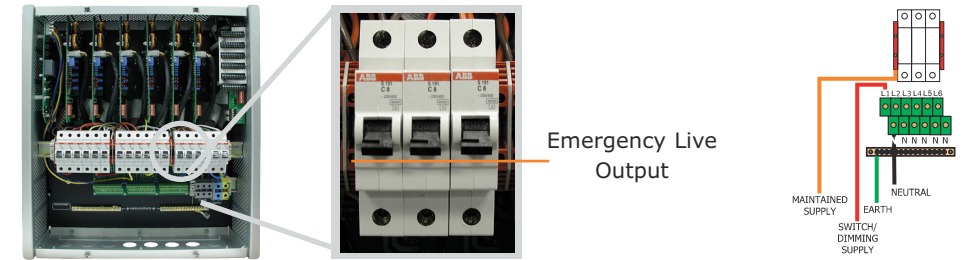

Load Types

The mains output of the Evolution Power and Processor Units can be configured to control various load types. On 6A and 10A models certain load types can be configured manually allowing circuit setup to be completed prior to commissioning of control plates and other devices. This allows the installer to check circuit operation without the need for a programmer.

	Load Ratings	Resistive Load	Inductive Load	Switched Load	Manual / Software Configurable
EVO-10-06 EVO-10-12	10A (9A Inductive)	2400W	2400W	2400W	Manual or software
EVO-06-09 EVO-06-18	6A (6A Inductive)	1500W	1500W	1500W	Manual or software
EVO-03-18 EVO-03-36	3A (3A Inductive)	750W	750W	750W	Software only

6A and 10A Modules (EVO-10-06, EVO-10-12, EVO-06-09, EVO-06-18)

Mains Dimmable Loads

The default settings for every mains output is dimming mains. This is a leading edge controlled output and is suitable for resistive or inductive loads upto its maximum ratings detailed above.

Mains Switched Loads

Units rated at 6A or 10A per circuit (EVO-06-09, EVO-06-18, EVO-10-06 and EVO-10-12) can have circuits individually set to operate in a switching only mode. This is configured by using simple links or the individual dimming modules.

The links are fitted in the 'D' position (dimming) when built at the factory. To set the circuit to switched operation move the link to the 'S' position (switched). Each dimming module has a link for each channel, the dimmer modules within an Evolution Unit are fitted in circuit order from left to right. i.e. with an EVO-10-12 the first dimmer module operates circuits 1-2, the second board operates circuits 3-4 as shown in the example opposite.

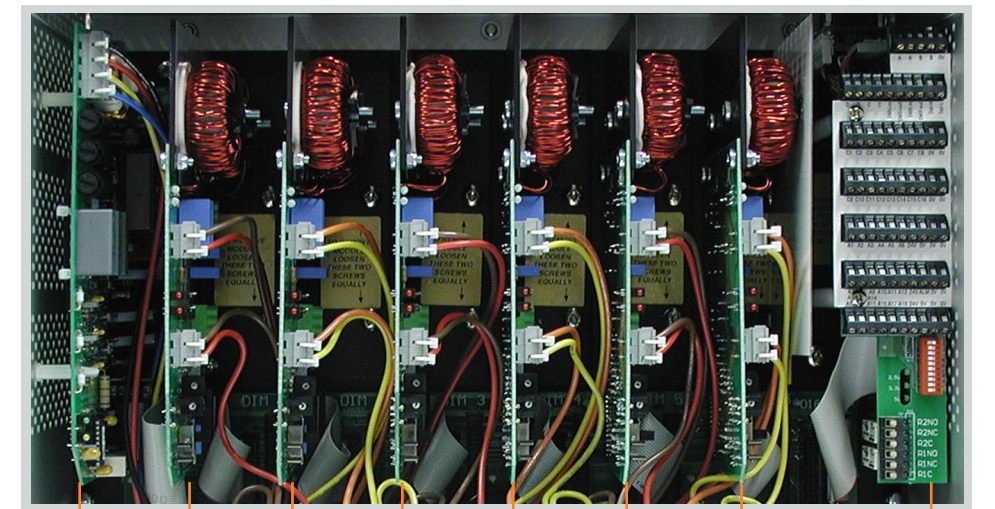

Important Note. Isolate power to the unit before changing link positions.

Picture shows 2 x 10A modules

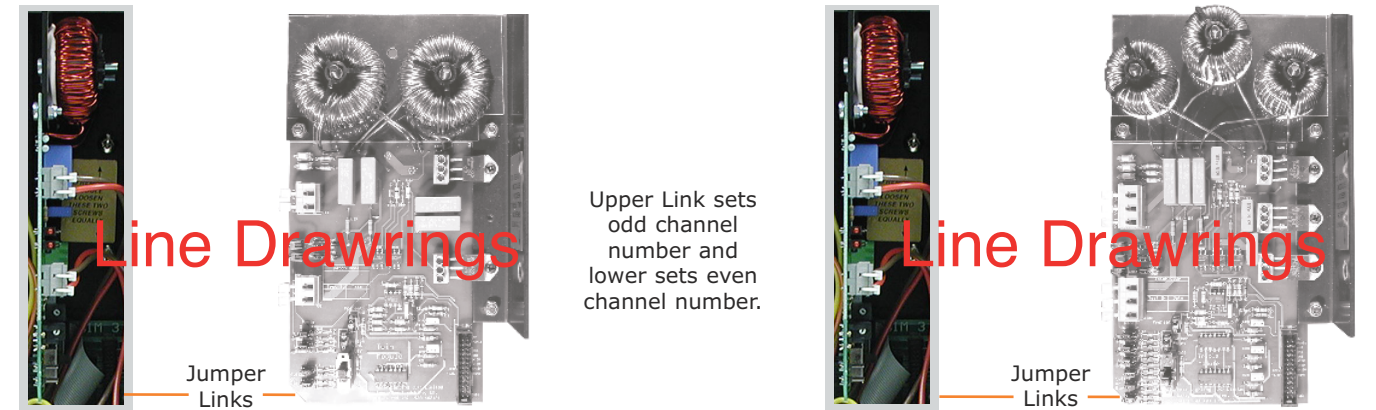

Line Drawings

Line Drawings

Upper Link sets odd channel number and lower sets even channel number.

3A Modules (EVO-03-18 and EVO-03-36)

The default settings for every mains output of an EVO-03-36 unit is switched operation this is to avoid dimming if switched only circuits when a system is first installed and prior to programming.

To set the output of either unit to dimmed operation please refer to the separate programming guide for instructions on how to do this.



All Pack Types

1-10V Fluorescent Loads

A 1-10V controlled ballast requires a switched 240V feed and a 1-10V control signal to operate. The mains output from an Evolution Power and Processor Unit can be set to switched operation as described above. Each mains output of an Evolution Unit has an associated 1-10V control signal. When using 1-10V fluorescent ballasts with an EVO-03-18 or EVO-03-36 the configurable outputs must be used for the 1-10V control signals. This signal can be used to drive 1-10V HF dimmable fluorescent ballasts. The +VE or 10V connection connects to the analogue terminal with the same reference number as the mains i.e. if a fluorescent load is connected to circuit 5, The 1-10V signal would be connected to A5 and 0V. The -VE or 0/1V cable is connected to the 0V terminal. See page 13 for example wiring for the 6A and 10A based units.

DSI Fluorescent Loads

A permanent mains connection which may be taken from one of the emergency outputs or a separate isolator as required. Each of the configurable 1/0's can be set (by software) to DSI operation. The positive DSI connection connects to the configurable terminal (C1-C16), the negative DSI connection is connected to the 0V terminal. See page 19 for example wiring. DALI is an extra feature. Please contact Mode Lighting if your project requires it.

DALI Fluorescent Loads (feature currently disabled)

A permanent mains connection is required which may be taken from one of the emergency outputs or a separate isolator as required. The DALI control connectors are taken to the DALI H and DALI L terminals as required. See page 16 for example wiring.

Evolution Power Units - Digital Board/Low Voltage Connections

All Evolution Power and Processor Units utilise the same digital control module. This holds the full power of the Evolution system. Features include:-

M-Bus:- This is the Network that connects Evolution devices together. Power and Processor Units, Control plates, Relay interfaces and RS232 interfaces all use this 4-core power and data network.

DMX Input:- Accepts standard 512 channel DMX input for triggering of scenes or pass through for override control of Evolution Unit DMX output. Connect to DMX IN+, DMX IN- and 0V.

DMX Output:- 128 Channel DMX output. Standard DMX 512 (1990), operation. Suitable for control of DMX fixtures (moving heads, LED's, colour changing etc). Connect to DMX OUT+, DMX OUT- and 0V.

Configurable I/O Options.
Options independently selectable through PC software.

Contact Input:- Allows a contact closure to trigger functions of the Evolution system for example a photocell, PIR or simple switch may be used to activate or enable a particular scene/event. Connect between C terminals and 5V.

0-10V Input:- Allows a control signal from a potentiometer, light sensor, analogue control etc to activate a scene/event or adjust a level or value within the system. Connect between C terminals and 0V.

DSI Output:- For each control of DSI dimmable fluorescent ballasts (Tridonic, Luxmate type). Connect between C terminals and 0V.

1-10V Output:- Suitable for level control of analogue 1-10V controlled ballasts or 1-10V controlled devices. Connect between C terminals and 0V.

Analogue 1-10V Output:- Channel associated 1-10V output for control of HF 1-10V fluorescent loads when required. (Up to eighteen channels on any power/processor unit).

Contacts:- Two volt free changeover contacts for interfacing/motor control/signalling.

RS232 Port:- (Mounted on top of unit). Used for bi-directional communication for integration with AV systems and operation of RS232 enabled devices.

M-BUS Port:- (Mounted on top of unit). Localised M-BUS port for connection of M-BUS devices or connection of programming kit.

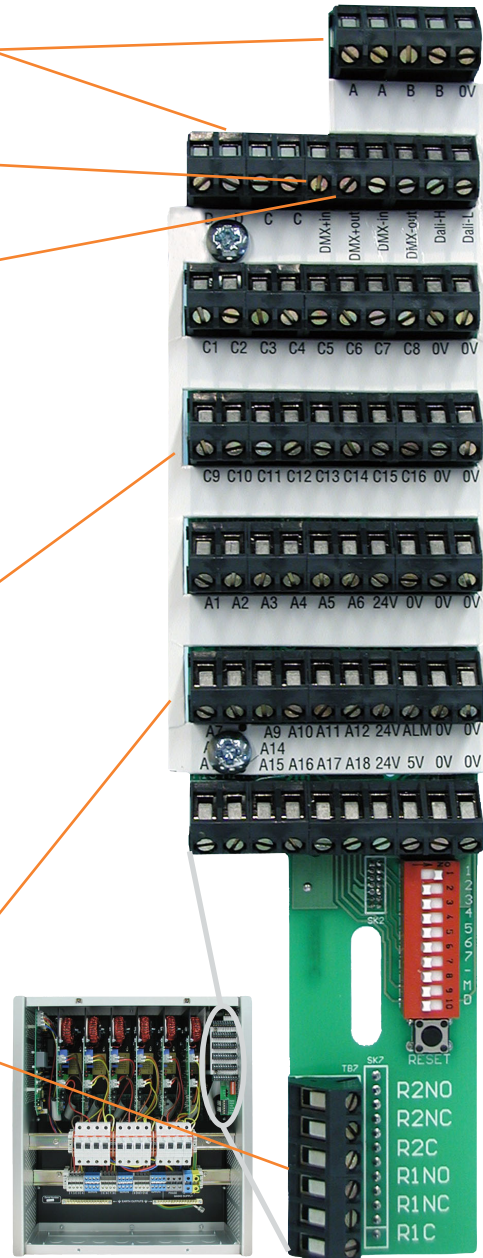

IMPORTANT NOTE!

If any of the items connected to the configurable terminals C1-16 are switched input devices, you should disconnect them from the pack before performing a firmware update. To disconnect contact-closure inputs you need only remove the 5v connection.

This is because during the firmware-update the processor is disconnected from the configurable terminals, which may then float to 12v as outputs.

M-Bus Wiring

The M-Bus connects all Evolution devices, such as packs, plates and relay units together. It carries both power for the plates and other peripherals, and the proprietary data to tell all devices what to do. The M-Bus consists of four connections, marked A, B, C and D. Connect A, B, C and D on the first device, to the corresponding A, B, C and D terminals on the second device, and so on.

A daisy-chain method of wiring should be deployed, rather than wiring the devices in a star-topology. See the diagram on page xxxx for an example. Most devices, including packs and plates, have two sets of A, B, C and D terminals. It does not matter which of the two A terminals is used as "in" and which is used as "out" when daisy-chaining as they are internally connected. The same is true for the B, C and D. Terminal A must never be connected to B, C or D etc.

The maximum bus length is 1000m (if you need to exceed this length, please contact Mode Lighting for more information about bus extender units).

Whilst star-wiring is not permitted, you may connect a short spur of no more than 100m to the bus at any point. Up to three spurs are permitted on any one network. Spurs do not require termination, as long as they are shorter than the overall network.

M-Bus Termination

The bus must be terminated at both "open" ends. Termination is achieved using DIP-switch 9 on the packs, and DIP-switch 10 on the plates. No more than two devices on the network should be terminated. The termination switches place a 120Ω resistor across the C and D terminals of the M-Bus.

M-Bus Cable Requirements

The M-Bus cable requires four conductors (two for power, and two for data). The "power" pair (A and B) should be no less than 0.5mm². The data pair (C and D) should either be shielded or twisted.

We recommend Belden 1502R cable.

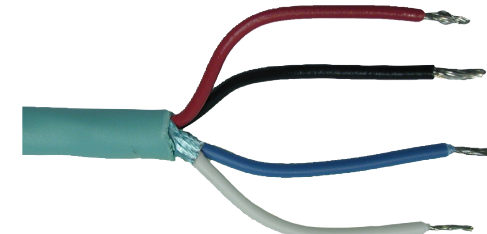

Using Cat 5 Cable

The popular Cat 5 type of cable may be used. However, cat-5 cable has the disadvantage that the conductors are very small and therefore are not good at carrying the power from the packs to the bus devices. This is because cat-5 cable was originally designed for carrying data only on local computer data networks. On relatively small M-Bus networks, with just a handful of devices, this is not a problem, however to overcome this difficulty we recommend that the thin cat-5 conductors be bunched together. We recommend the following standardised wiring:

- A Group all three solid-colour cables together, except the brown wire
- B Group all three striped-colour cables together, except the brown/white striped wire
- C Brown/White Stripe
- D Solid Brown

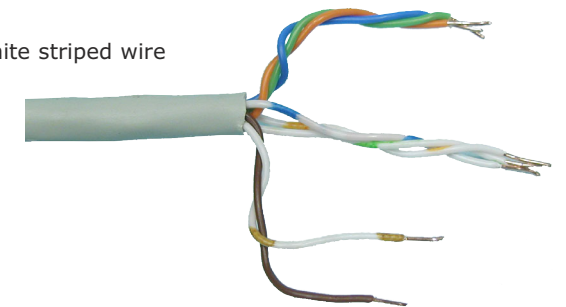

If the cable runs are relatively short, and only a handful of devices are on the bus then you only need to use two conductors for each of A and B.

Testing the M-Bus Wiring

With the power switched off, a basic test of the M-Bus wiring can be performed with an ohms-meter as follows:

With the bus terminated at just one end the measurement should be approx 120Ω. With both bus terminations correctly switched on (one at each end of the bus) the measurement should be approx 60Ω.

Between A and C or A and D should be approx 4MΩ – 8MΩ. Likewise between B and C or B and D there should be approx 4MΩ – 8MΩ. If either of these measures a short-circuit then the unit has suffered internal damage, and you should contact Mode Lighting (UK) Ltd for advice.

To test any one device on its own (to check for internal damage), remove it from the network and, with the bus termination switched off, measure between C and D. This should be approx 37kΩ.



Verifying Correct Bus Operation At Power-Up

When the Evolution system is powered up wait for 10 seconds, until the green M-Bus power LED has illuminated (see section entitled "Diagnostics – Power Supply LEDs" for more details).

All plates on the system should perform the factory-default operations (See page xxxx for more details). However if the plates are flashing a sequence of Red-Green-Blue on all of the buttons then one of the following problems requires attention:

1. Bus Wiring Fault. Check that C and D are not shorted, swapped, or misconnected in any way.
2. Bus Termination Fault. Check that just two terminations, on the ends of the bus are in place using the DIP switches on the pack(s) and plate(s).
3. Pack DIP-switch fault. Check that all the packs have been set to the correct address, and that DIP switch 7 (firmware update mode switch) is off (i.e. set to the left).
4. Incorrect bus topology. Check that the total bus length is less than 1000m, that any spurs are less than 100m, and that the bus has been wired in a daisy-chain topology.

For more information about diagnostic indications on the plate LEDs see page xxxx.
For examples of bus wiring diagrams see page xxxx.

Diagnostics – Power Supply LEDs

The Power Supply module is located on the left-hand side of the Evolution pack, and has three neon lights and two LEDs, one green and one amber.

Neon Indicators - Mains

The three green neon lights indicate whether the fuses are in tact, and that the three mains feeds are healthy.

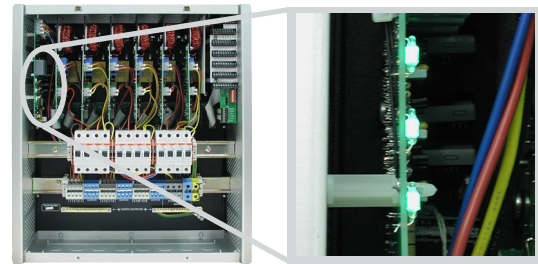

Green LED – M-Bus Power

The green LED indicates that the pack is supplying 24v to the M-Bus. After power is supplied to the pack there is a delay of approximately 10 seconds before the bus is powered, and during this time the LED will be off. If the LED remains off after 10 seconds then power-down the pack and check for a short-circuit across the A and B terminals of the bus.

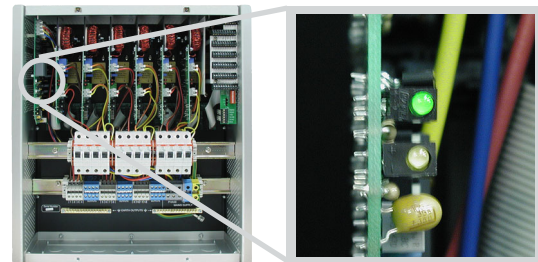

If the green LED flashes it indicates that a heavy current is being drawn on the bus. This could be due to a short circuit at the end of a long length of bus cable, or it could indicate that you have too many plates or other bus devices connected.

A combined maximum of 20 LCD plates or 100 Single-Gang Plates may be used per pack on the network.

Amber LED - Mains

The amber LED is also an indication of the incoming mains supply. If all three phases are healthy then the amber LED will remain continuously lit. However if one or two phases fail then the LED will flash to indicate which phase is at fault.

One flash, followed by a pause, indicates that phase one is faulty. Two flashes, followed by a pause, indicates that phase two is faulty. Three flashes indicate that phase three is faulty. If two phases are faulty then there will be a number of flashes for the first faulty phase, then a pause, then a number of flashes for the third faulty phase. If all three phases are faulty then there will be no electricity with which to flash the LED, and so it will remain un-illuminated.

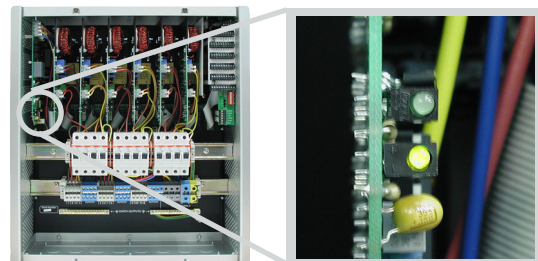

If any of the green neon indicators are illuminated but the amber LED is not illuminated then the PSU module has been damaged, and will require replacement. Please contact Mode Lighting (UK) Ltd for advice and spares.

Red LEDs On Digital Board – Low Voltage Power

There are three red LEDs, visible through a slot in the terminal board that show that the three low-voltage power supplies used by the processor are healthy. If any of the three LEDs is not illuminated then the unit will not function correctly.

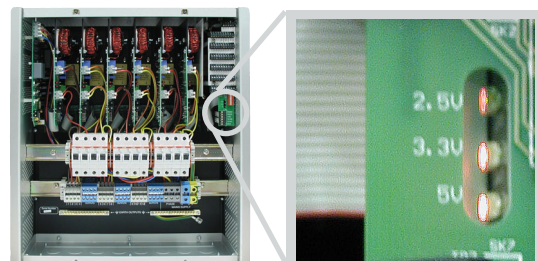

Amber LEDs On Digital Board

There are three amber LEDs, also visible through the slot in the terminal board. These indicate specific processor activity.



Appendix - Wiring Examples

Evolution Digital Board.

Found in top right hand side of the Power and Processor Unit.

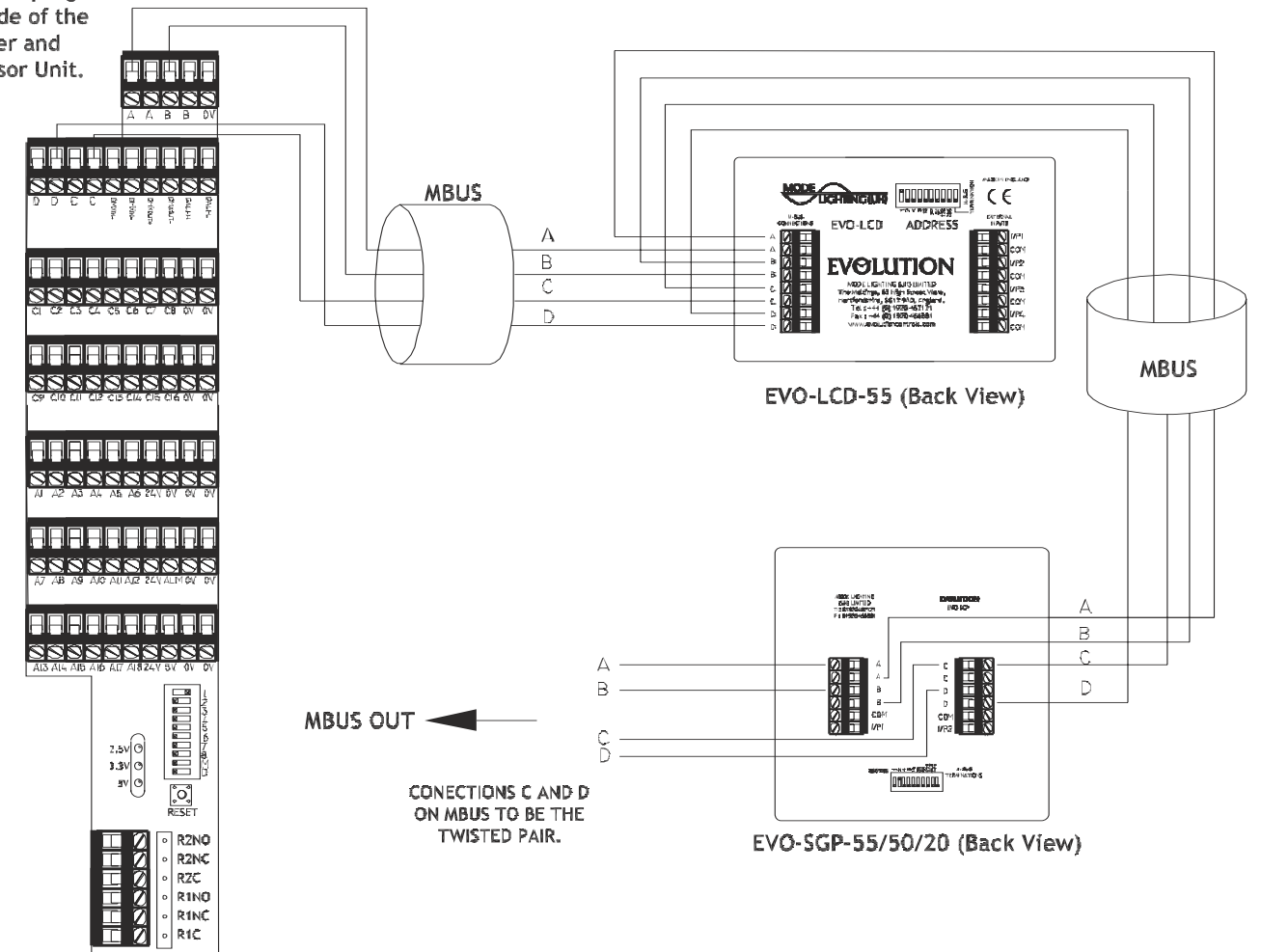

1-10V Output using Outputs A1-A18

Using Power and processor Units EVO-06-09, EVO-10-06, EVO-10-12, EVO-06-18

1-10V Output to Ballast using Analogue Terminals A1-A18

Example :- Circuit 1 Used for 1-10v Ballat Operation.

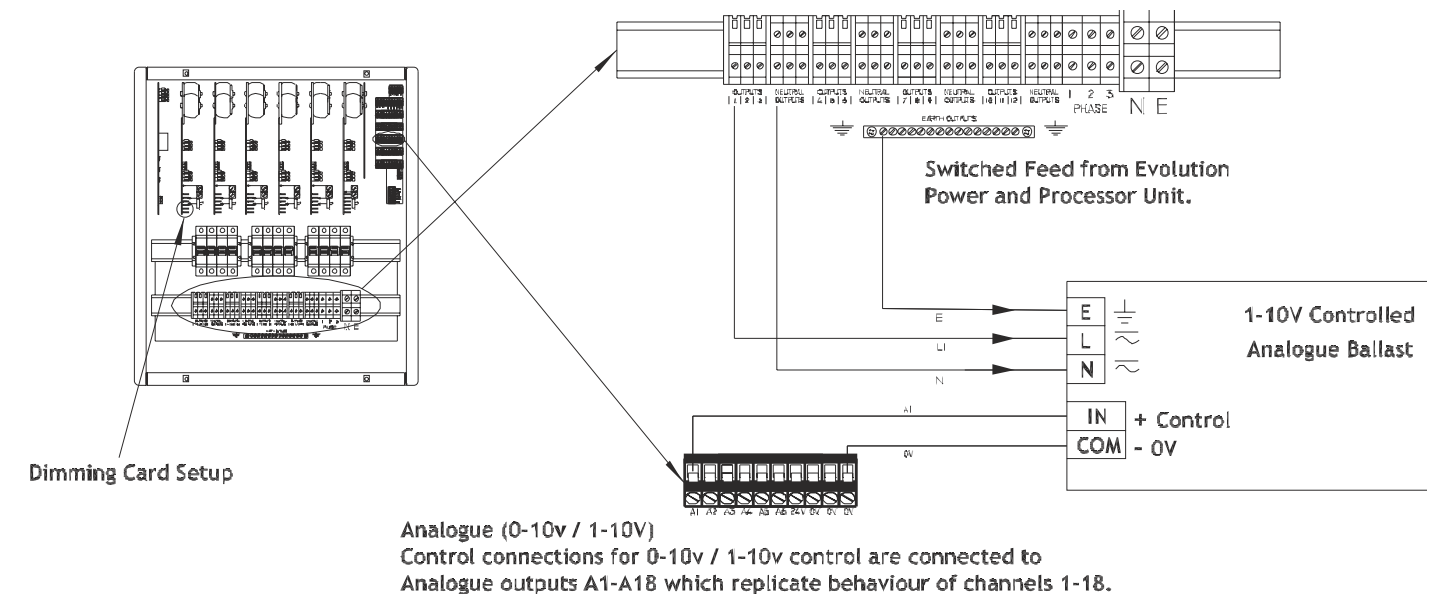

Analogue (0-10v / 1-10V)
Control connections for 0-10v / 1-10v control are connected to Analogue outputs A1-A18 which replicate behaviour of channels 1-18.



Using Evolution Power and Processor Units EVO-03-18 and EVO-03-36

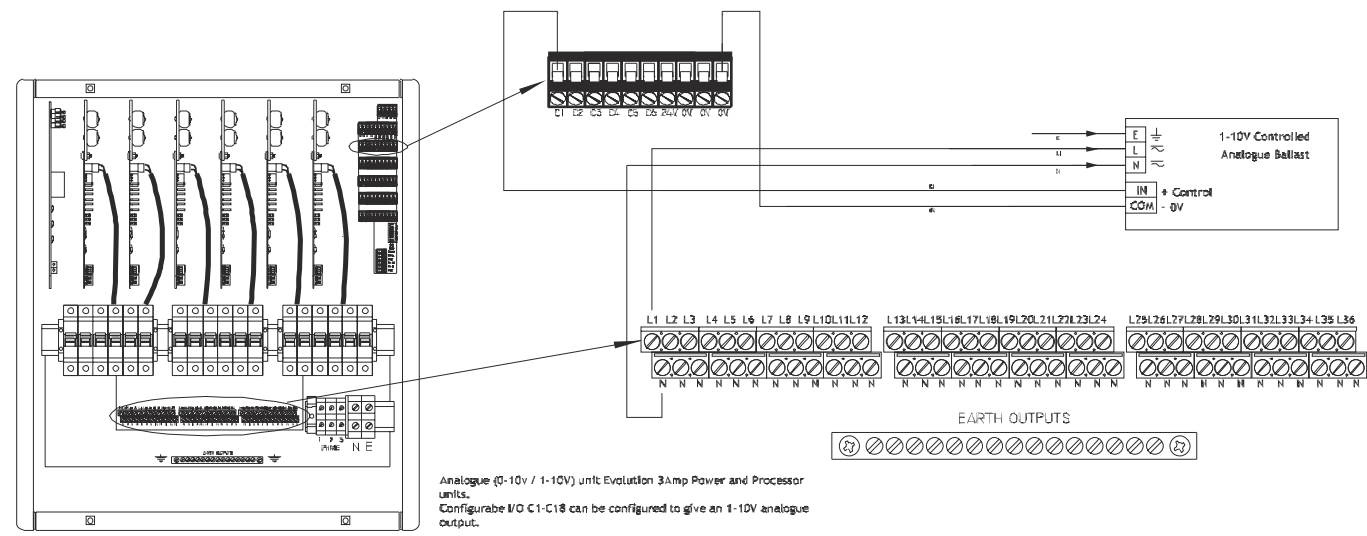

Analogue (0-10v / 1-10V) unit: Evolution 3Amp Power and Processor units. Configurable I/O C1-C18 can be configured to give an 1-10V analogue output.

DMX Input Example

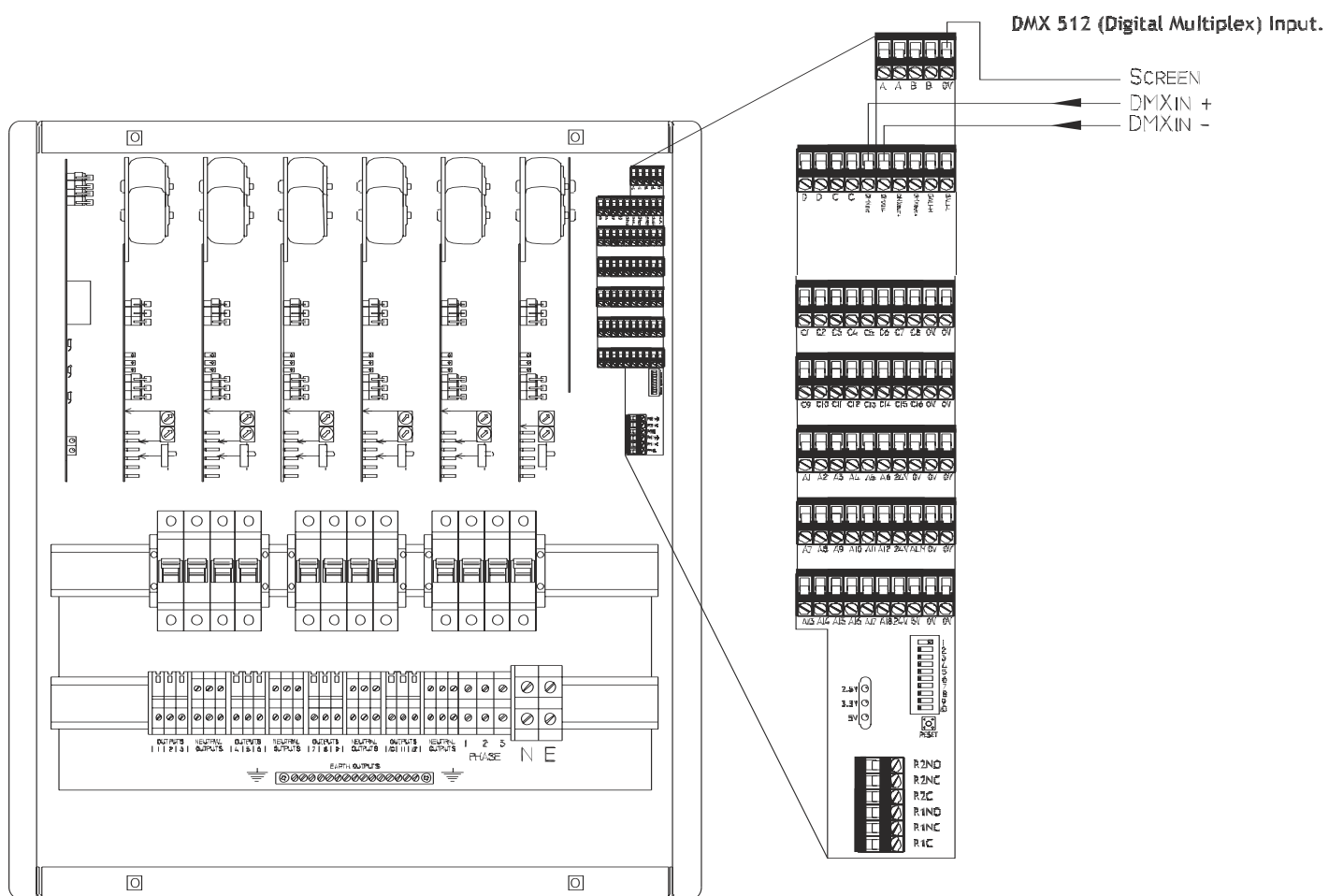

Configurable Input/Output Options

Contact Inputs
Power and Processor Unit Contact Closure Example.

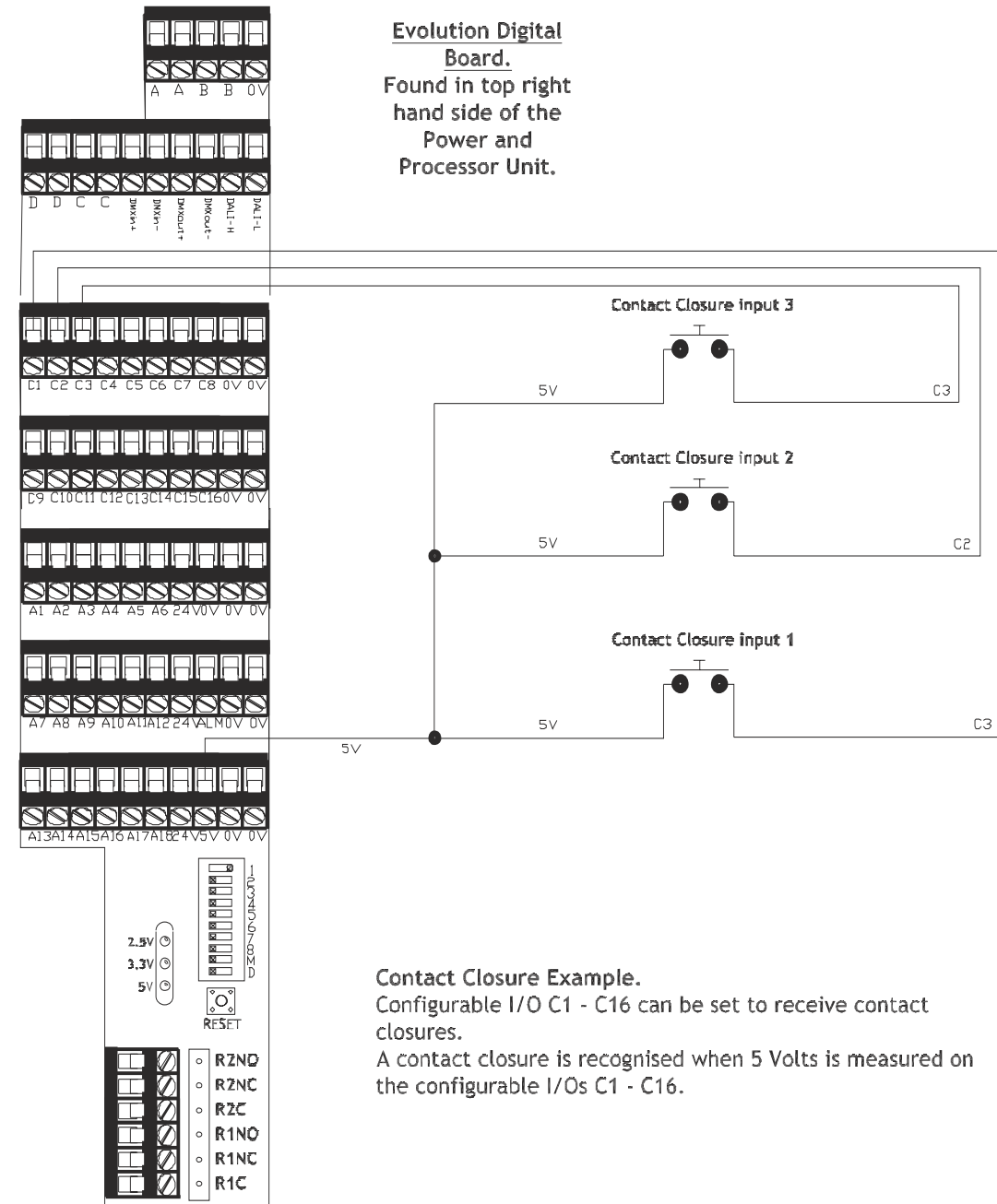

Evolution Digital Board. Found in top right hand side of the Power and Processor Unit.

Contact Closure Example. Configurable I/O C1 - C16 can be set to receive contact closures. A contact closure is recognised when 5 Volts is measured on the configurable I/Os C1 - C16.



DMX OUTPUT EXAMPLE

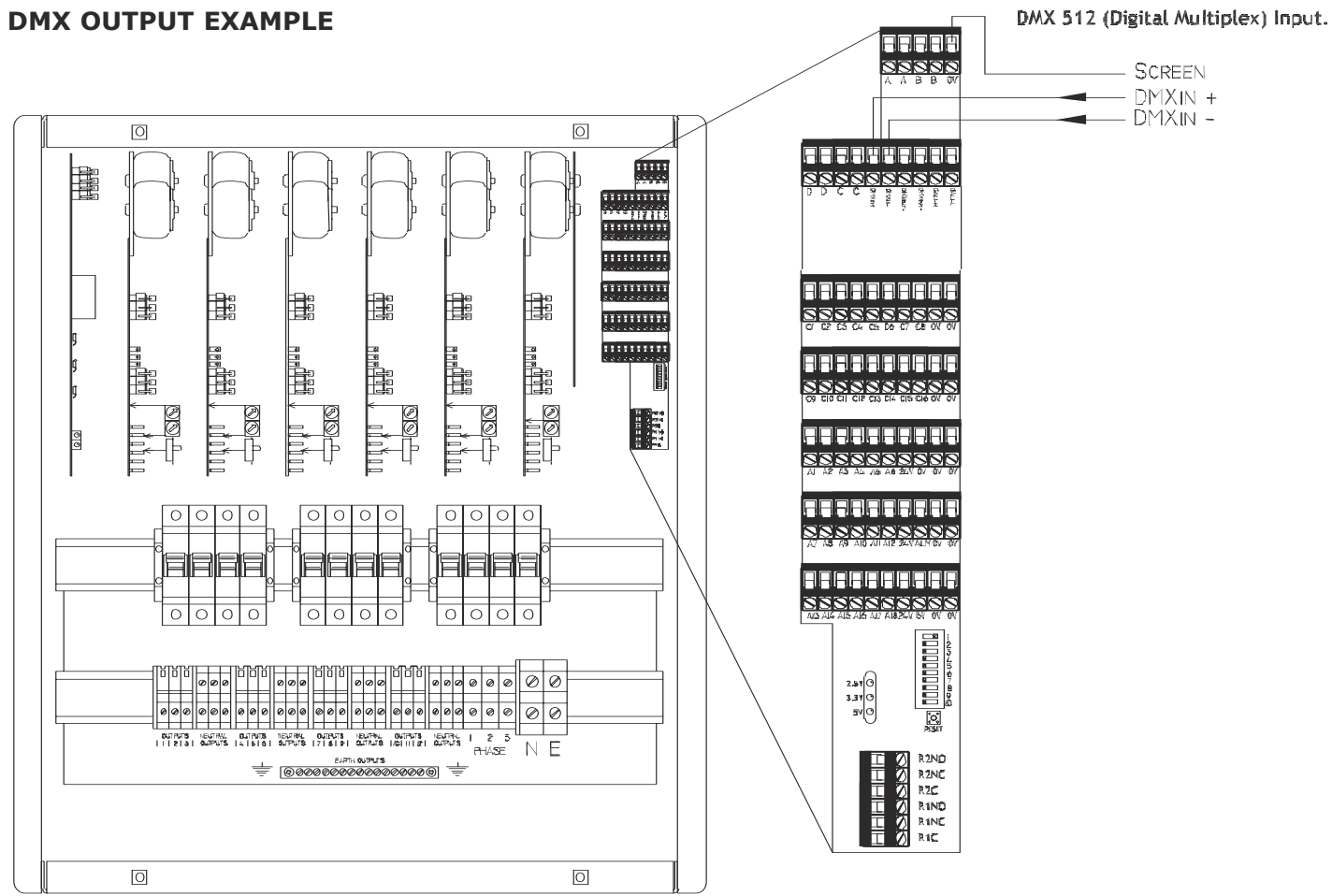

Onboard Relay Contractors



Evolution Digital Board.
Found in top right hand side of the Power and Processor Unit.

Relay Legend Key.
R1C - Relay 1 Common Connection.
R1NO- Relay 1 Normaly Open Contact.
R1NC - Relay 1 Normaly Closed Contact.

R2C - Relay 2 Common Connection.
R2NO- Relay 2 Normaly Open Contact.
R2NC - Relay 2 Normaly Closed Contact.

Onboard Relay operation illustration.

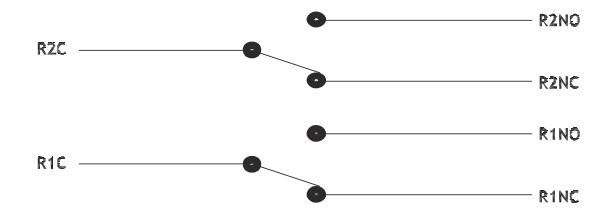

DALI Output

Evolution Digital Board.
Found in the top right hand side of the Power and Processor Unit

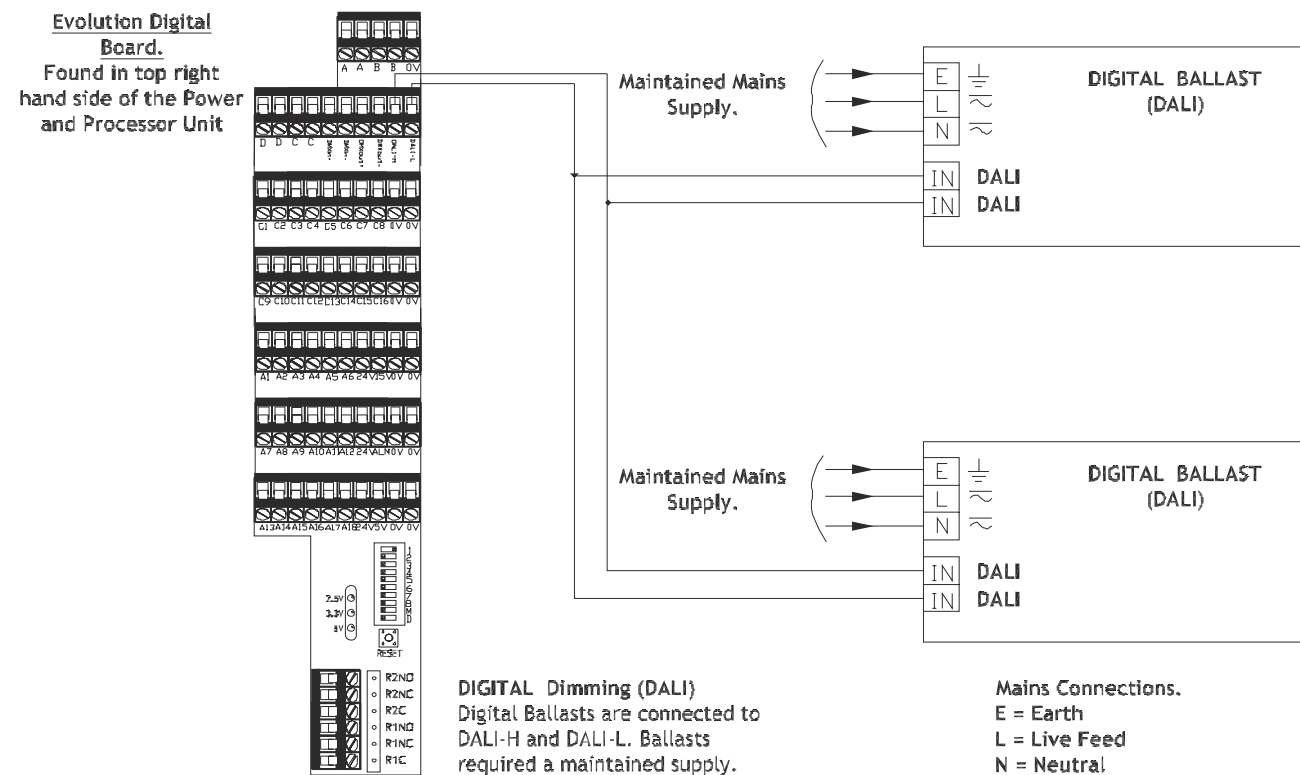

NB DALI Has not yet been implemented in Firmware and therefore must not be used. Please contact Mode Lighting (UK) Ltd for details.

1-10V Inputs

0-10V Input using the Mirage SD-00-04 Slider.

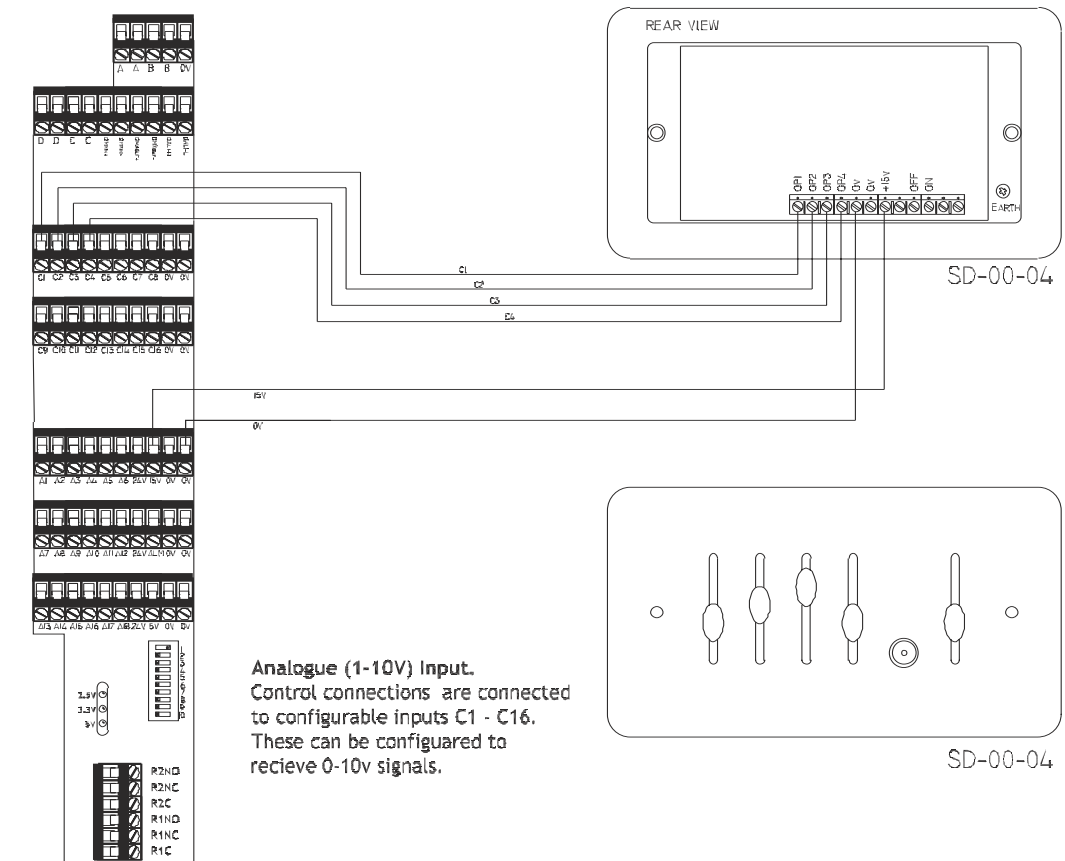



0-10V Output using Configurable Terminals. (Fluorescent Ballast as an example)

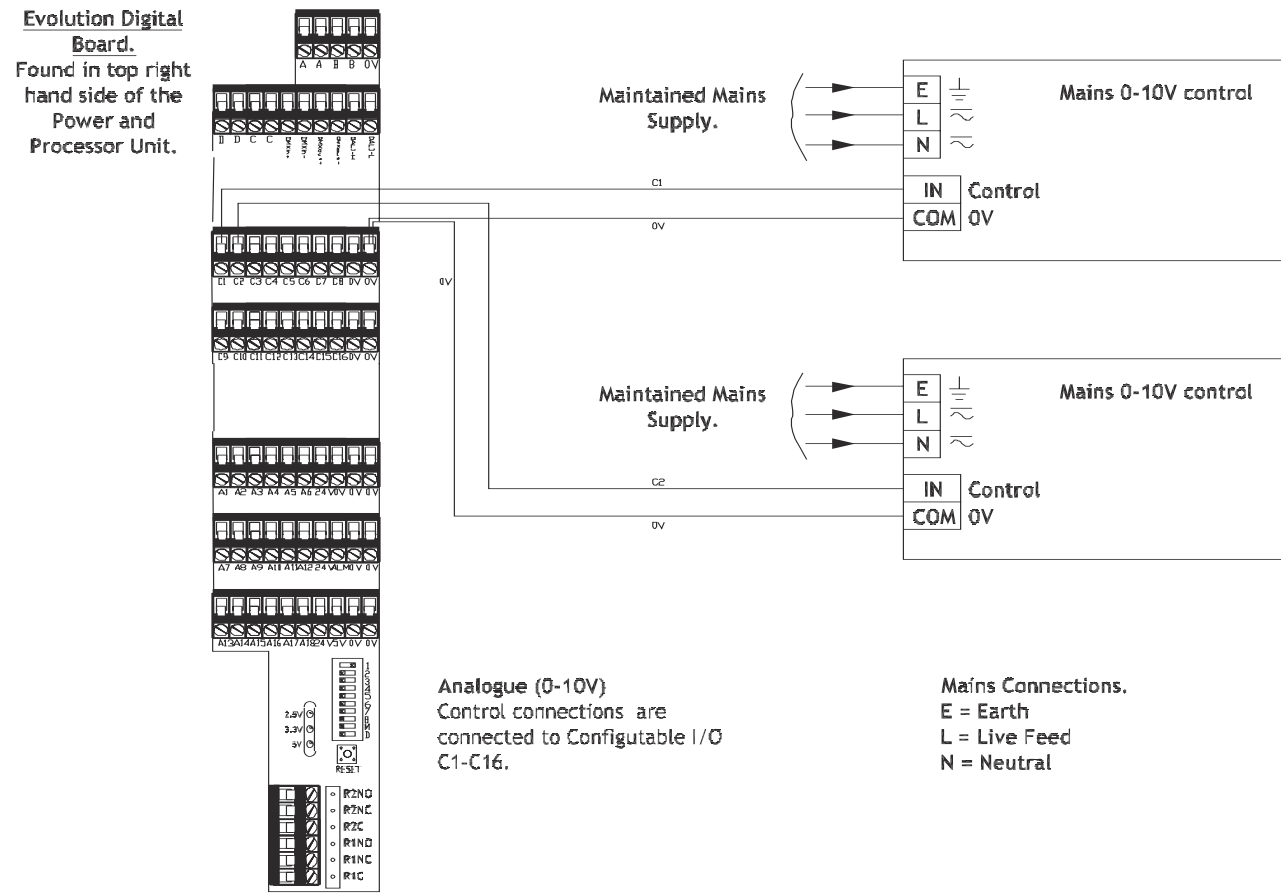
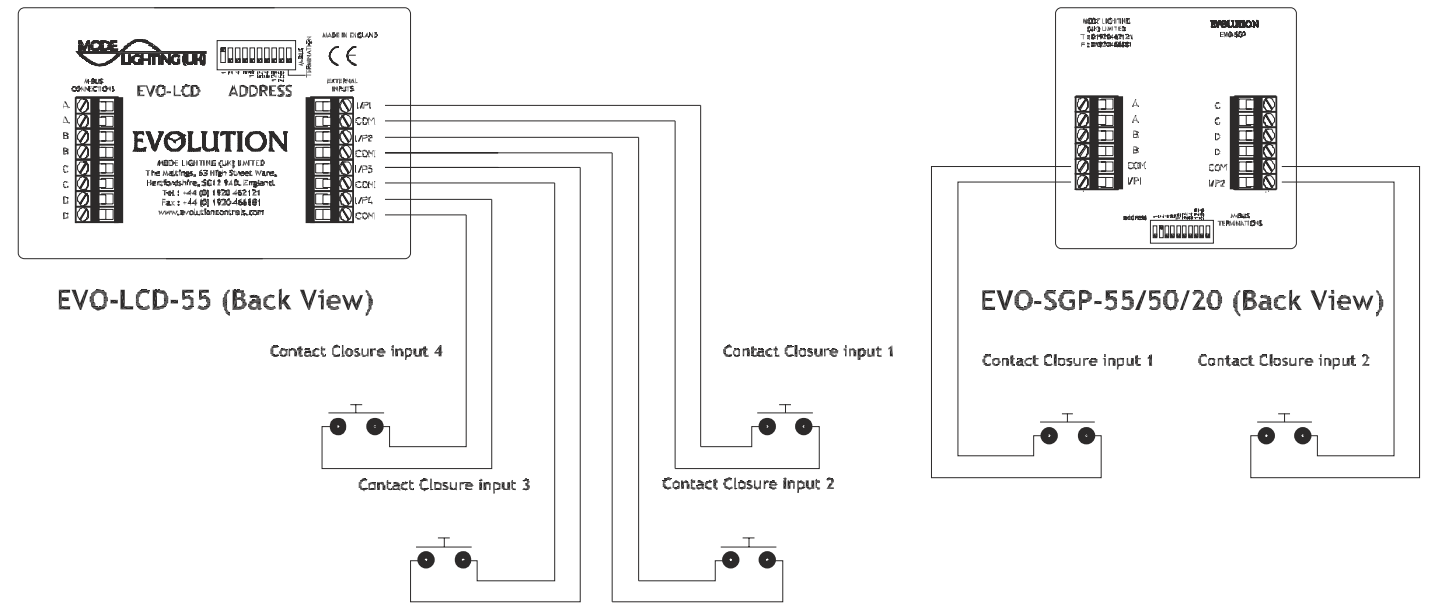
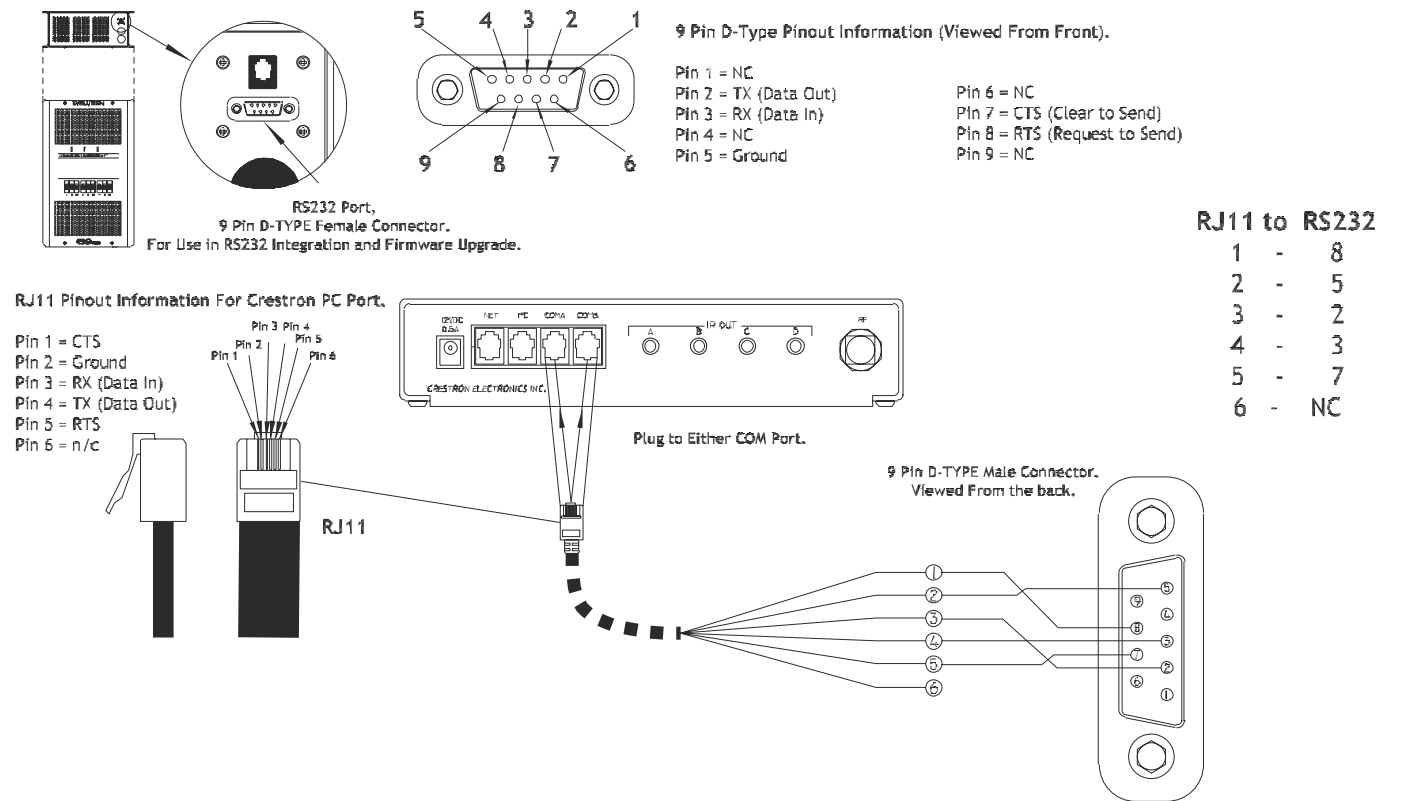

Plate Contact Closure Example



Connection to a CRESTRON System

Crestron ST-CP Processor to Evolution Power and Processor Connection Example.



DSI Output using Configurable Terminals

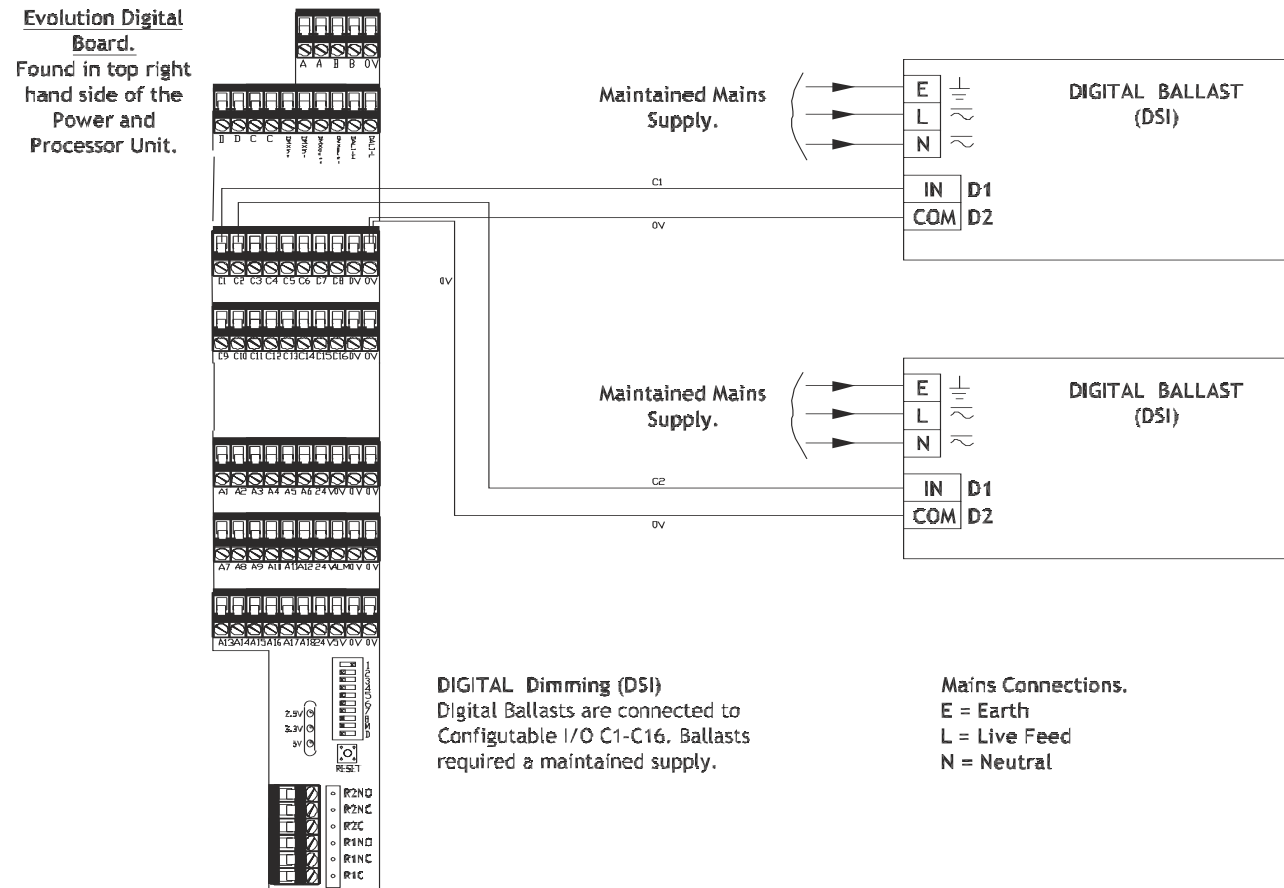



Connection to a CRESTRON System

PC to Evolution Power and Processor Connection Example.

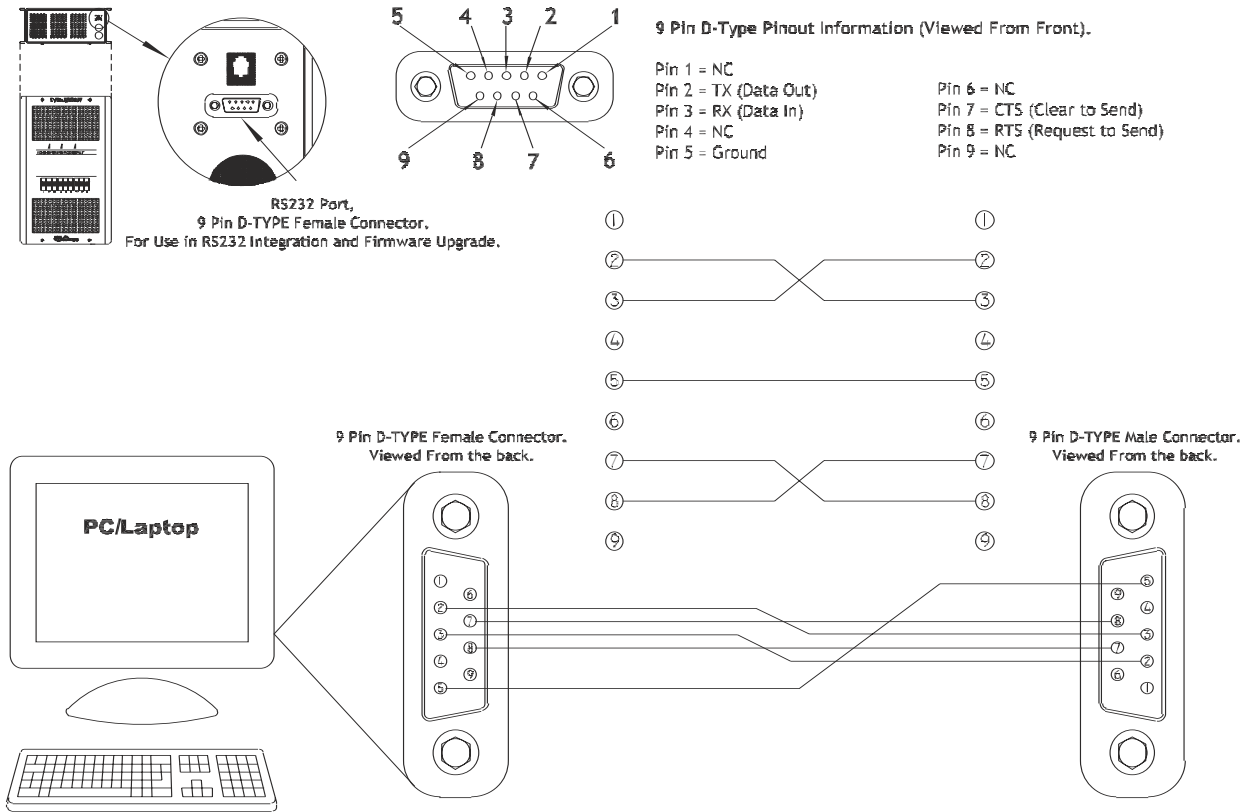

Connection to an AV System or Computer via RS232

Crestron ST-CP Processor to Evolution Interface EVO-INT-232.

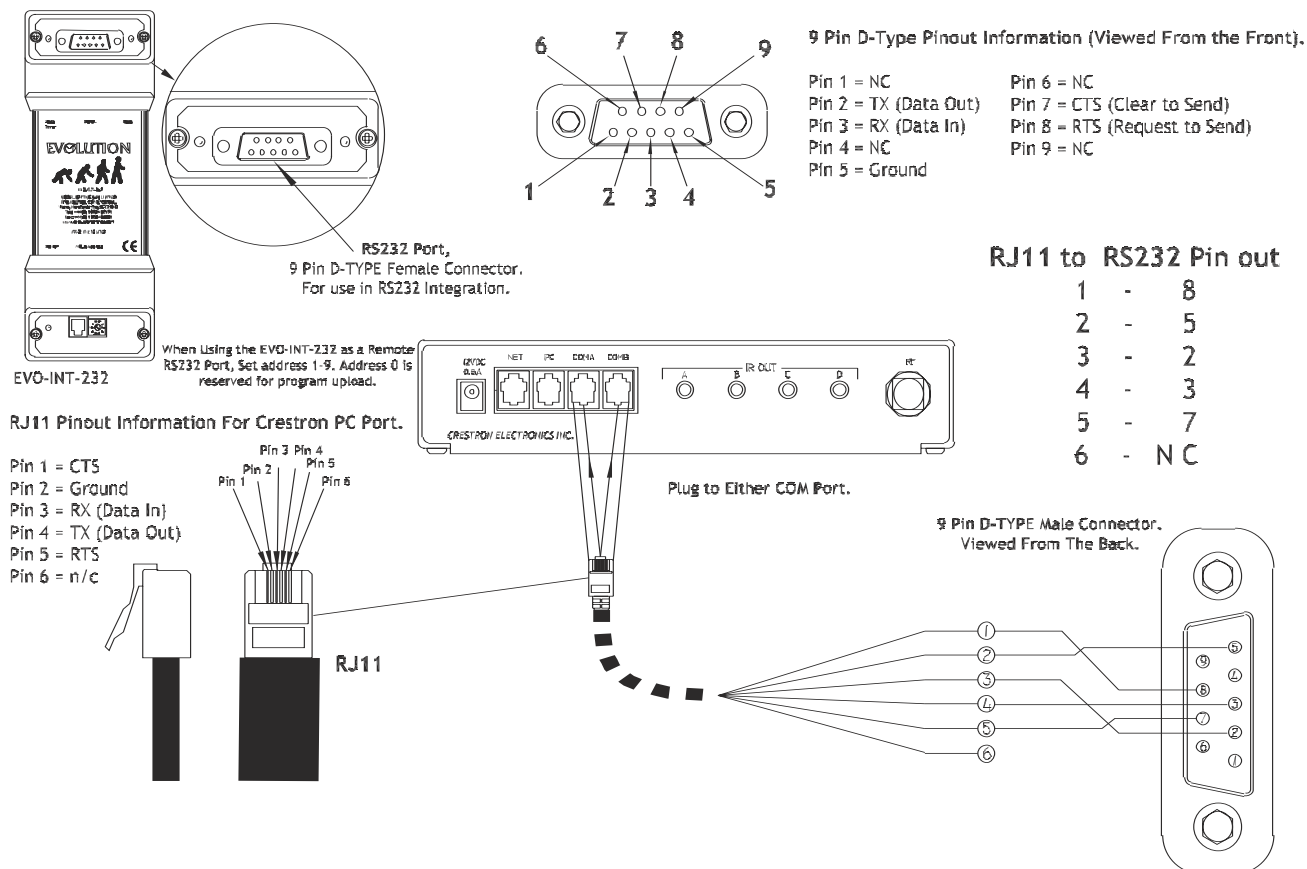

Factory Reset Procedure

WARNING - This procedure will clear all information programmed into a system and will return all devices on a power and processor unit to factory default behaviour.

Evolution Digital Board. Found in top right hand side of the Power and Processor Unit

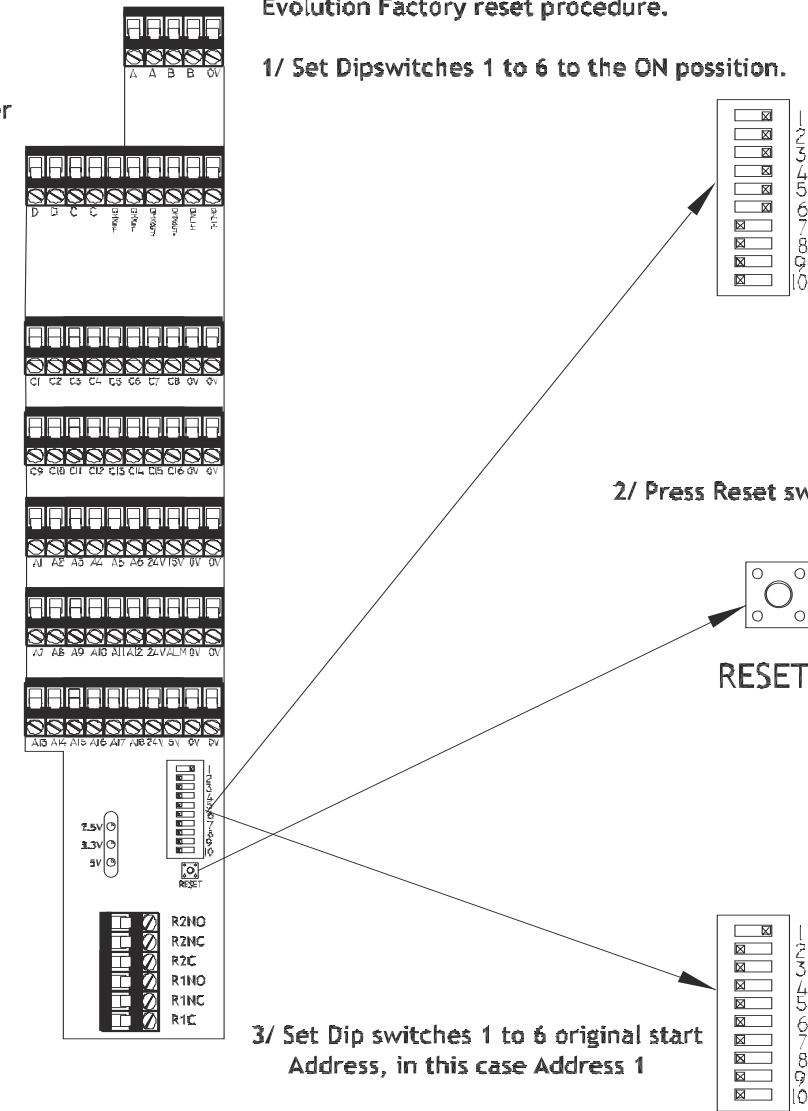

1. Set DIP switches 1-6 ON (i.e. switch in the right-hand position)
2. Press and hold the reset button for 5 seconds
3. Wait for one minute (whilst the pack restores it's default settings)
4. Change the DIP switches back to the pack address required

When using the factory-default settings all of the plates connected to a network control all of the channels on all of the packs as follows, using a 3-second fade time:

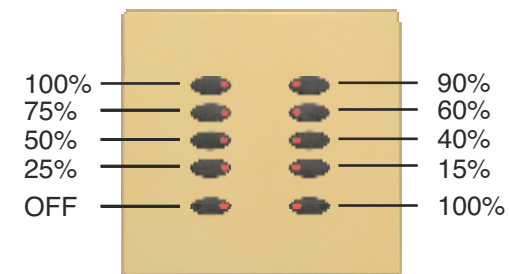

On a two button plate the buttons give on/off.



Setting Up a PC For Diagnostics and Testing Using HyperTerminal

A PC running Windows and HyperTerminal may be used to perform basic control and diagnostic functions with the Evolution system.

Connect a 9w D-D straight-through serial cable between a COM port on your PC, and the RS232 port on the top of an Evo pack. We recommend a cable such as RS part code 287-9460 for this purpose.

HyperTerminal should have been installed on your computer, as it forms part of the Microsoft Windows package. Click on the Start menu, and then follow through Programs->Accessories->Communication to find it.

If this is the first time you have used HyperTerminal for communicating with the Evolution system then you will need to set up a new connection.

1. Enter any name, and select any icon. Then click OK.

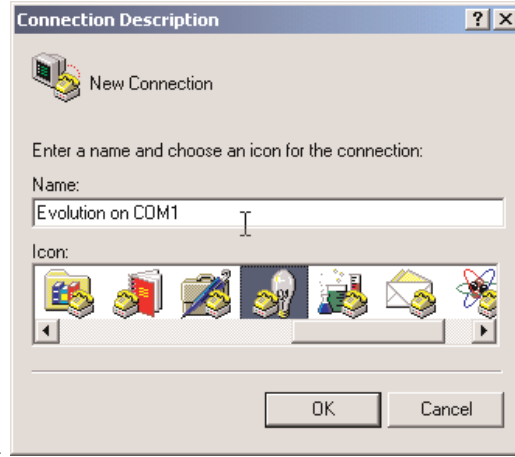

2. At the next dialog, select the COM port which you are using for the serial connection to the pack.



3. Click OK. In the dialog that follows, set the COM port properties as shown right:

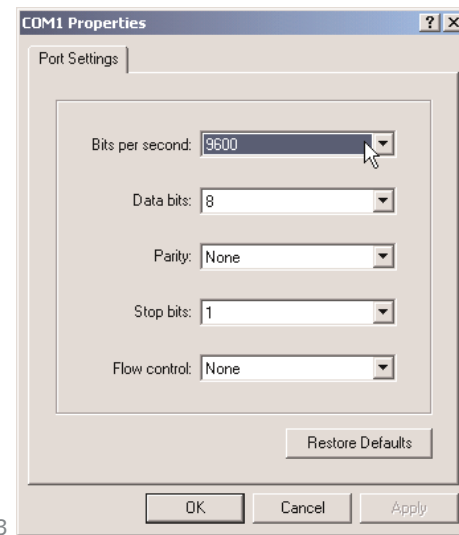

4. Click "Disconnect" from the call menu or click on the disconnect icon

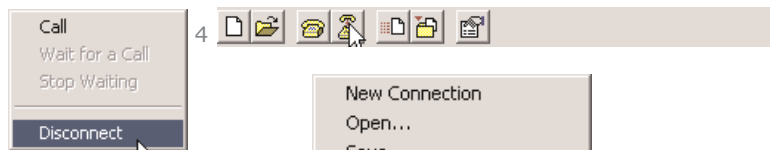

5. Then click on the Select "Properties" from the file menu

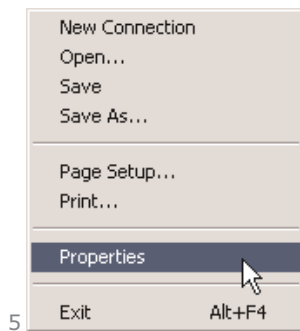

6. Click on the "Settings" tab, and then on the "ASCII Setup..." button.

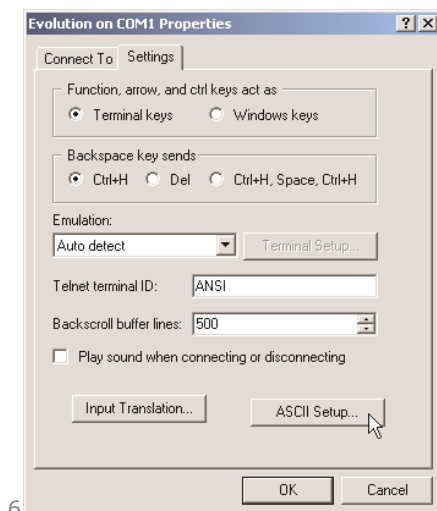

7. Tick the "Echo typed characters locally" box, then click OK on both property dialog boxes.

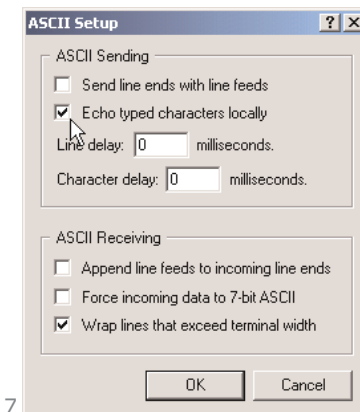

8. You may now click on the Connect icon, or select "Call" from the Call menu:



HyperTerminal sends the characters that you type on the computer keyboard directly to the Evolution pack, and displays any text that is returned. As characters that you type are transmitted immediately this basic terminal interface does not permit the use of cursor keys or the delete key.

Type the command EVOSYS (in capital letters) into HyperTerminal. The Evo pack should reply, as shown below:

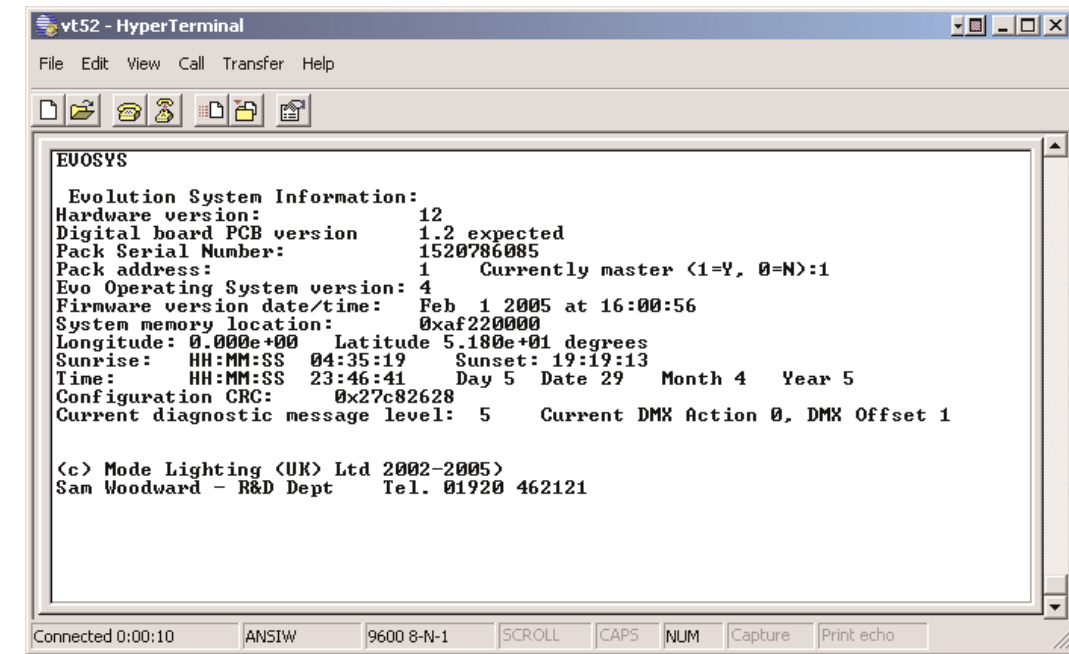

This gives you details of the hardware and firmware versions, the current pack address, as well as the current time and sunrise/sunset calculations. It also confirms that the pack is running correctly, communicating with the RS232 port and has the correct time.

Diagnosis of M-Bus Problems Using HyperTerminal 'N' and 'B'

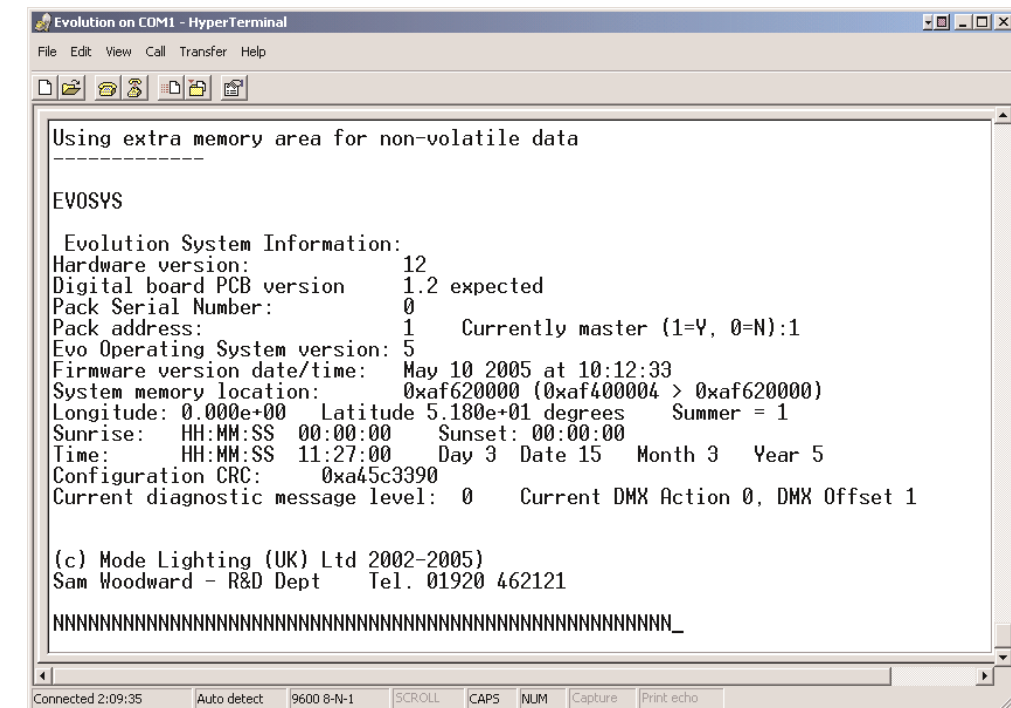

If the bus is incorrectly wired, has not been terminated properly, or is damaged then the character 'N' (meaning No bus) will be printed, approximately once per second.

Follow the instructions on page xxxx regarding bus wiring to rectify this problem.

The 'N' characters will stop once the pack has successfully connected to the bus. If they do not you may need to reset the processor module in the pack by holding down the reset button for five seconds.

If there are wiring errors on the bus, for example if the C and D connections have been swapped over on one or more bus devices, but occasional messages are able to be transmitted between other bus devices then the character 'B' (For Bus Error) will be printed. Check the wiring of C and D on all bus devices to rectify the problem.



Changing BIOS Settings

There are a number of parameters that can be set to define the pack's operation. To see a list type the command BIOSLIST

```

Evolution on COM1 - HyperTerminal
File Edit View Call Transfer Help
Time: HH:MM:SS 11:27:00 Day 3 Date 15 Month 3 Year 5
Configuration CRC: 0xa45c3390
Current diagnostic message level: 0 Current DMX Action 0, DMX Offset 1

(c) Mode Lighting (UK) Ltd 2002-2005)
Sam Woodward - R&D Dept Tel. 01920 462121

«EVOLUTION by Mode Lighting (UK) Ltd. BIOS Settings:
BIOS01 (Digital Input 1 Threshold) 10
BIOS02 (Digital Input Filter) 4
BIOS03 (Digital-In Ch for diag.) 0
BIOS04 (Digital-In Held length) 3
BIOS05 (DMX delay, 99=Off) 0
BIOS06 (DSI repeat 1=On, 0=off) 0
BIOS07 (No. of DMX Channels to TX) 4
01=16, 02=32, 03=64, 04=128, 05=200, 06=256
BIOS08 (reserved for future use) 0
BIOS09 (reserved for future use) 0
BIOS010 (Half-sec sequencing mode) 0

Use command BIOSnnVxxS to set parameter nn to value xx
    
```

Type BIOSnnVxxS to set parameter nn (always two digits) to value vv (always two digits).

The BIOS parameter values are as follows:

Parameter	Value	Meaning
1	10	The threshold for detecting a contact closure input on a digital configurable channel. This parameter can be raised to filter out noise spikes on the digital inputs, or lowered if there is no noise but you are using long cables and so an increase in sensitivity is required
2	04	Digital Input Filter This is the number of consecutive same-state readings that have to be observed before a change in state is considered valid on the digital input. Readings are taken approximately 20 times per second. If this number is raised then the system will be more immune to noise, however there will be a longer delay between a contact closing and any rule triggering an output scene.
3	00	This specifies a configurable channel for which current input level will be output from the pack via the RS232 port. A single byte is transmitted from the Evo pack every time the input is sampled (approx 20Hz) to show the current level in the range 0x00 to 0xFF. A value of 0 for BIOS parameter 3 switches off this stream of data.
4	03	Digital Input Held Length. This specifies the number of consecutive batches of contact closure cycles for a contact closure that will be translated as "held". This is most commonly used for Impulse-closed from a push button that has been wired into the configurable terminals on a pack.
5	00 or 99	DMX delay. By default this parameter is zero, increasing the value inserts some additional delay into the DMX data generated, which may be required for some older or non-standard DMX devices. A value of 00 switches off the DMX generator
6	00 or 01	DSI repeat. If set to zero then DSI data is only generated when the level changes, if set to 1 then new DSI data is sent every 10th of a second even if there is no change in output light level required. If you experience flicker problems then try switching off the DSI whilst you fault-find the wiring installation for sources of interference.
7	01, 02, 03, 04, 05, 06	Specifies the number of channels of DMX data to be generated 16 channels 32 channels 64 channels 128 channels 200 channels 256 channels The system operation will be more slick if only the minimum number of DMX channels that you actually require are transmitted. The DMX refresh rate is always 20Hz.
8	99	Default fade time for raise/lower/impulse in 10 th s of a second.
9	00	Unused
10	00	Used for enabling a special 1/2second rapid-sequencing mode. Contact tech support for further information if required.

Diagnostic Commands

There are a number of parameters that can be set to define the pack's operation. To see a list type the command BIOSLIST



The Evolution pack can output diagnostic messages, ranging from important error messages (for example if a 3A dimming card is removed and the processor can therefore not communicate with it) to details of which rules and scenes are being used. To set the level of diagnostic messages which are output use the command:

EVODnSET where n is one of the following values:

0. No messages. Only RS232 commands that have been set as outputs in scenes, and "fatal" errors, such as a bus fault 'N' will be output
1. Only serious errors, such a memory faults are output
2. Less serious errors and warning messages are also output
3. Diagnostic messages, such as which rules have been matched, and which scenes are being recalled are output.
4. Further diagnostic data, including memory usage reports, are output

The transmission of diagnostic messages, especially levels 3 and above, does slow down the operation of the rest of the system, and so it is preferable to switch off all diagnostic messages once the system has been commissioned to ensure slick operation.

Use the command EVOD0SET to switch off all diagnostic messages.
Use the command EVOD4SET to switch on full diagnostic output.

The current diagnostic message level setting is shown after typing an EVOSYS command in the HyperTerminal window:

```

EVOSYS
Evolution System Information:
Hardware version: 12
Digital board PCB version 1.2 expected
Pack Serial Number: 0
Pack address: 1 Currently master (1=Y, 0=N):1
Evo Operating System version: 5
Firmware version date/time: May 10 2005 at 10:12:33
System memory location: 0xaf620000 (0xaf400004 > 0xaf620000)
Longitude: 0.000e+00 Latitude 5.180e+01 degrees Summer = 1
Sunrise: HH:MM:SS 00:00:00 Sunset: 00:00:00
Time: HH:MM:SS 11:27:00 Day 3 Date 15 Month 3 Year 5
Configuration CRC: 0xa45c3390
Current diagnostic message level: 0 Current DMX Action 0, DMX Offset 1
    
```

LEVELS

The LEVELS command prints out a list of the current levels, and current scenes of all channels on the pack to which your RS232 cable is connected:

```

Evolution on COM1 - HyperTerminal
File Edit View Call Transfer Help
LEVELSConfig Channels:
Chan 1 (1) at 0x0 (0) Scn 0 (Dimmed)In 0
Chan 2 (2) at 0x0 (0) Scn 0 (Dimmed)In 0
Chan 3 (3) at 0x0 (0) Scn 0 (Dimmed)In 0
Chan 4 (4) at 0x0 (0) Scn 0 (Dimmed)In 0
Chan 5 (5) at 0x0 (0) Scn 0 (Dimmed)In 0
Chan 6 (6) at 0x0 (0) Scn 0 (Dimmed)In 0
Chan 7 (7) at 0x0 (0) Scn 0 (Dimmed)In 0
Chan 8 (8) at 0x0 (0) Scn 0 (Dimmed)In 0
Chan 9 (9) at 0x0 (0) Scn 0 (Dimmed)In 0
Chan 10 (10) at 0x0 (0) Scn 0 (Dimmed)In 0
Chan 11 (11) at 0x0 (0) Scn 0 (Dimmed)In 0
Chan 12 (12) at 0x0 (0) Scn 0 (Dimmed)In 0
Chan 13 (13) at 0x0 (0) Scn 0 (Dimmed)In 0
Chan 14 (14) at 0x0 (0) Scn 0 (Dimmed)In 0
Chan 15 (15) at 0x0 (0) Scn 0 (Dimmed)In 0
Chan 16 (16) at 0x0 (0) Scn 0 (Dimmed)In 0
Power Channels:
Chan 1 (17) at 0x7f800000 (100) Scn 2 (Dimmed)
Chan 2 (18) at 0x7f800000 (100) Scn 2 (Dimmed)
Chan 3 (19) at 0x7f800000 (100) Scn 2 (Dimmed)
Chan 4 (20) at 0x7f800000 (100) Scn 2 (Dimmed)
Chan 5 (21) at 0x7f800000 (100) Scn 46 (Dimmed)
Chan 6 (22) at 0x7f800000 (100) Scn 46 (Dimmed)
Chan 7 (23) at 0x7f800000 (100) Scn 46 (Dimmed)
    
```

DMXLIST

This lists the current DMX levels and current scene on the DMX generator, and the current level of the channels of the incoming DMX universe.

For further details of RS232 commands, see the Evolution Software Manual, available from Mode Lighting (UK) Ltd.



APPENDIX A: UPGRADING POWER AND PROCESSOR PACK FIRMWARE

A utility is provided to enable commissioning engineers to upgrade the operating system (i.e. the firmware) of the Evolution Power and Processor Packs if a newer version has been produced since the packs were shipped from Mode Lighting.

The firmware file, which contains the Evolution operating system, should not be confused with the configuration (.evo) file.

The firmware in a pack may be upgraded by connecting a PC to the pack directly using the RS232 socket located on the top of the pack. Each pack must be upgraded individually because, unlike the configuration data, it is not possible for the packs to self-update their firmware.

All new packs are supplied having been already pre-loaded with an operating system and therefore you should only perform a firmware upgrade if instructed to do so by Mode Technical Support.

Updates to the operating system firmware are supplied in a file called "evoflash.hex". This file is included on the distribution CD, and is also available on the Evolution Controls website, as well as by email from Mode Technical Support,

To check whether you have the latest version of the Evolution Operating System Firmware contact Mode Lighting on +44 1920 462121.

Installing the DLL File: Windows 95/98/ME Users

Before running the application EvoFirmUp.exe you need to copy the DLL file flashtc1775.dll from the Evolution software installation disc into the C:/Windows/System folder on your PC.

Installing the DLL File: Windows 2000/XP Users

Before running the application EvoFirmUp.exe you need to copy the DLL file flashtc1775.dll from the Evolution software installation disc into the C:/WINNT/System folder on your PC.

If the DLL file has not been copied then the following error will appear when EvoFirmUp.exe is launched:

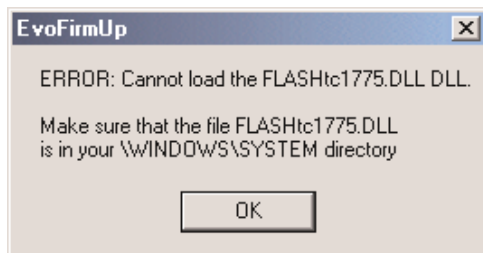

IMPORTANT NOTE!

If any of the items connected to the configurable terminals are input devices, you should disconnect them from the pack before performing a firmware update. To disconnect contact-closure inputs you need only remove the 5v connection.

This is because during the firmware-update the processor is disconnected from the configurable terminals, which may then float to 12v as outputs.

The Upgrade process is in three steps:

1. Select the new firmware file and com port

Click on the "Select firmware file..." button to open a standard "Open" dialogue. You need to locate the firmware file named "evoflash.hex".

Select the COM port that you have used to connect to your pack from the drop-down list of available ports. If the port that you wish to use is not included in the list then it is probably in use by another application. Close the other application and drop-down the list again. The upgrade program will automatically default to the first available port.

2. Put your pack into "Firmware Upgrade Mode" and cycle the power.

"Firmware upgrade mode" is selected by setting the pack's DIP-switch number 7 to the ON position.

3. Ensure that you have a connection between the PC and the pack, and click on the button shown to start the upgrade process.

A small window will be displayed, and should remain on the screen for up to three minutes.

A message box will then appear to indicate a successful upgrade, or to indicate if there were problems.

4. Select "normal running mode" on the pack by switching DIP switch 7 off, and cycle the power again.

Further detail of the process, possible error messages, and solutions are shown in the flowchart on opposite page:

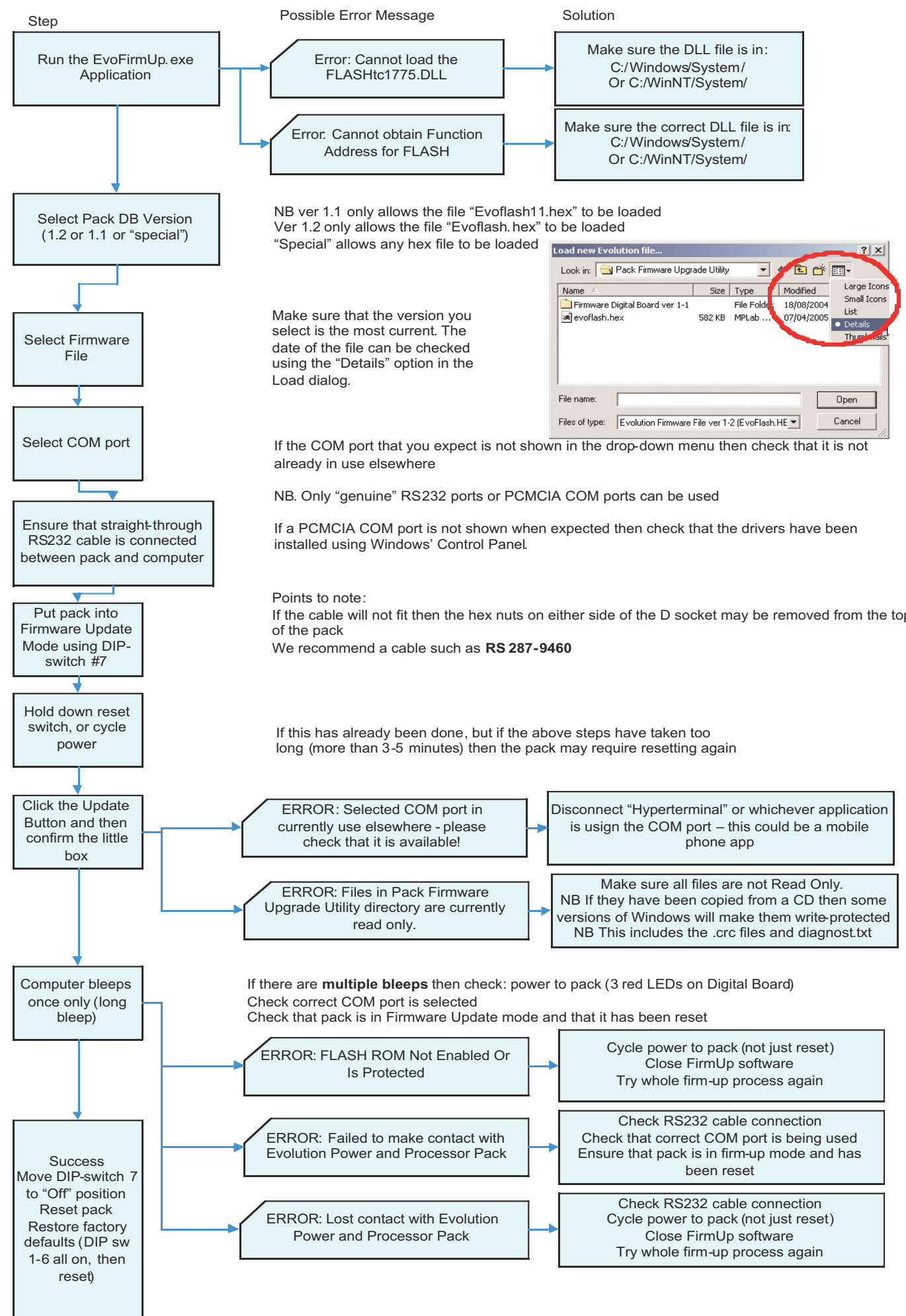



Appendix - Device Address DIP-Switch Settings

The Evolution System key feature is to enable any button on any plate control any output or event on the system. The way that this is achieved is by allocating an address to each pack, plate, or other device on the network. Other devices include relay units or ceiling mounted Infrared Detectors. The addressing of devices uses the binary numbering system.

In the normal decimal numbering we are used to using digits 0-9 in the right-hand column representing the number of 1's in a number, then the next digit to the left being the number of 10's, the next the 100's and so on. Each column represents ten times the value of the previous column. Therefore, for example, the number 56 is made up of $5 \times 10 + 6 \times 1$.

In Binary only values of 0 and 1 are used to show each digit of a number. The right-most digit represents the number of 1's in the number (either 0 or 1), then the next column represents the number of 2's, the next the 4's and so forth. Each column represents twice the value of the previous column. Therefore address 1 is: 0001, address 2 is 0010, address 3 is 0011 (i.e. one two, and one one), address 7 would be 0111 (i.e. a 4+2+1). The binary numbering system is used because, with each column being either a 1 or 0, an on/off switch can be used to represent the number.

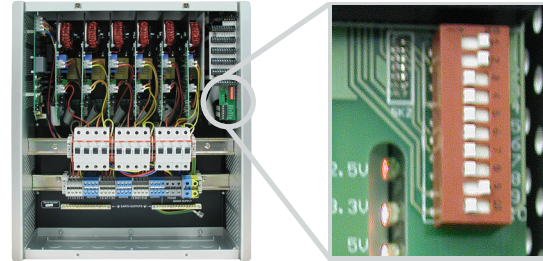

The following diagram demonstrates the dipswitch settings required to give an individual address to a plate in an Evolution Systems.





Appendix – Port Wiring Diagrams

Programming M-Bus Port

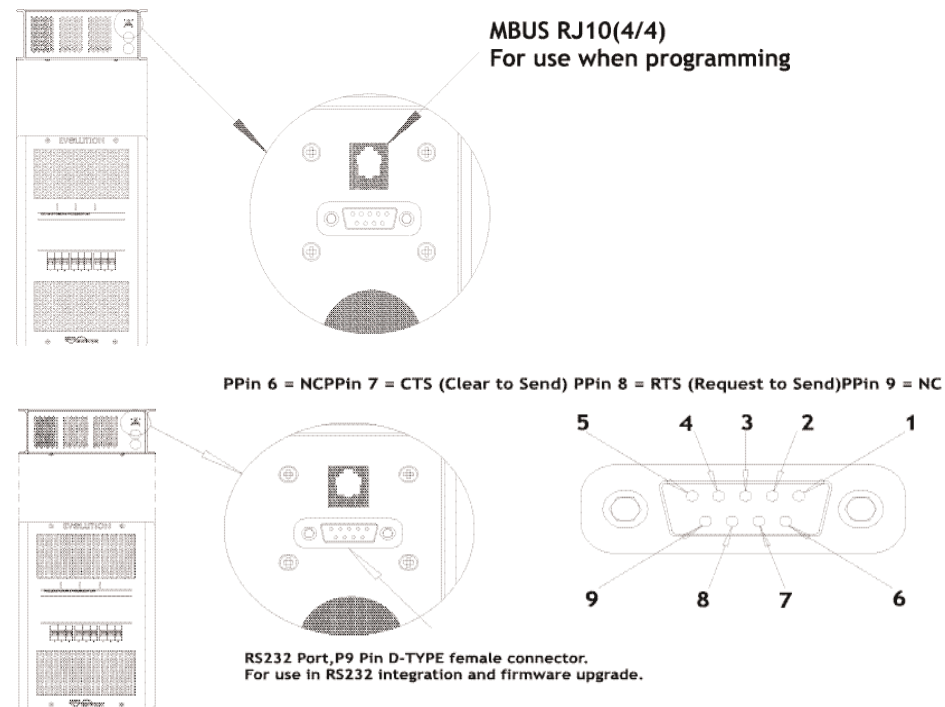

The RS232 port always has the following data settings:

Baud Rate	9600
Data bits	8
Parity	None
Stop bits	1
Handshake	RTS/CTS (though HyperTerminal may be run with "None")

NB Extra RS232 ports in the form of EVO-INT-232 devices connected to the M-Bus may be configured to use different data settings using the Evolution PC software.

Control Plate Installation

Evolution Control Plates require a backbox with a minimum depth of 35mm, however we recommend a deeper backbox if possible, to allow the maximum room for cables.

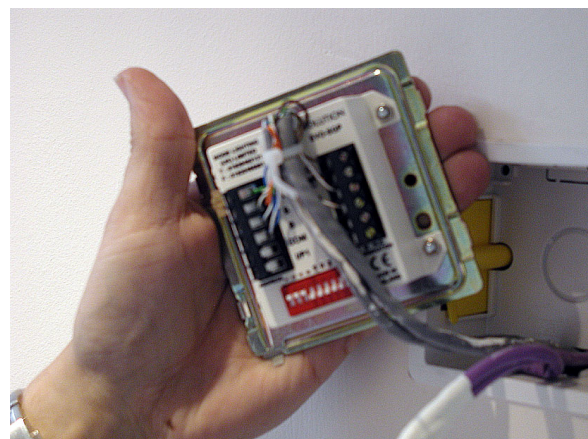

1. With the packs switched off, so that the bus is not "live", connect the A, B, C and D bus wires to the terminals on the back of the plate.
2. A cable-tie, provided with the plate, may be used to secure the cables onto the back of the plate.
3. Set the plate address, using the DIP switch. The binary numbering system (see Appendix xxxx) is used. Ensure that the wiring cannot cause the DIP switches to move when the plate is fitted into the backbox. The plate address may be checked using the technique described in the next chapter.
4. If the plate is the last item in the bus' daisy chain then set the bus termination, using DIP-switch number 10.

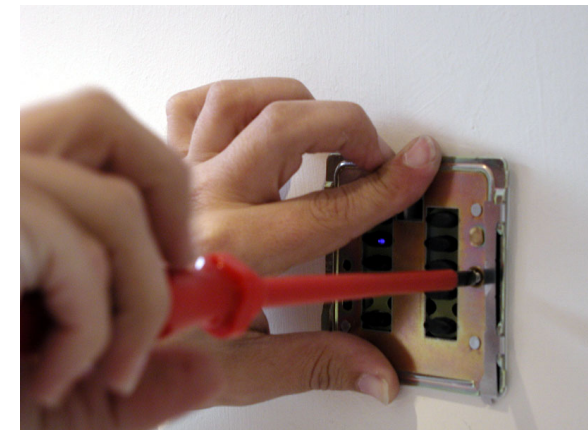

5. Screw the plate to the back-box using the screws provided with the plate. NB it is important to use the flat-headed screws provided, and not normal dome-headed screws as they would prevent correct attachment of the fascia. If the wall is uneven then be careful not to over-tighten the screws as this would bend the plate. (If you require more long flat-head screws then please contact the Mode Lighting (UK) Ltd spares department, quoting part number SN283)

Fitting The Fascia Plate

6. Normally the fitting of the fascias would be delayed until after the wall has been painted, and other non-clean building tasks have been finished.

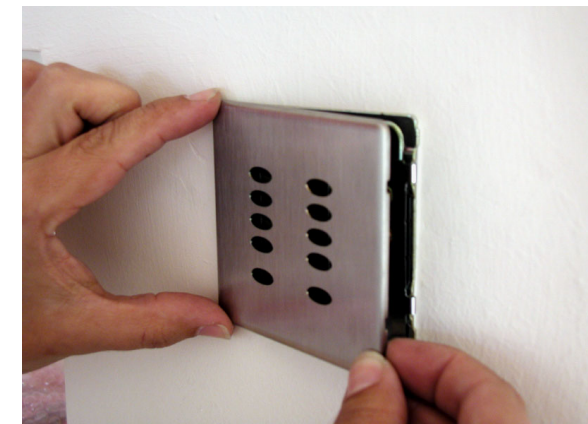

7. To fit the fascia, align the left hand side first, clipping it onto the side of the plate.
8. Ensure that all the buttons are able to fit through the holes, you may need to wiggle them slightly to ensure that they will not be trapped behind the fascia.
9. Align the right-hand buttons, if there are any.



10. Firmly press the top-right and then the bottom-right corners of the fascia until it clicks into place.
11. Check that all of the buttons are properly protruding through the holes in the fascia.

When testing the plates, remember that the M-Bus power is not produced by the Power and Processor Units until ten seconds after they have been powered-up. Therefore the LEDs on the plates will remain un-illuminated until the green M-Bus power LED on the pack is illuminated.

Check the LEDs on the plates. If they flash red-green-blue in sequence then there is a bus wiring or termination fault. Follow the instructions on page xxxx to rectify this.



How To Remove A Fascia Plate



The fascia may be removed by inserting a 4mm flat-head screwdriver under the tap that protrudes from the bottom-right corner of the plate, and performing a 1/4 turn twisting action. Be ready to catch the fascia as it detaches from the false-plate to avoid damage in dropping it.

Control Plate Diagnostics

Plate LEDs flashing Red-Green-Blue in Sequence

This indicates that there is an error in the bus wiring, termination or processor board connections. See page xx for more information



Plate LEDs flashing Red Pairs in Sequence

This indicates that the plate does not have an address. Unscrew it from the wall, and set an address using the DIP switch on the rear of the plate. See page xxxx for details of address codes.

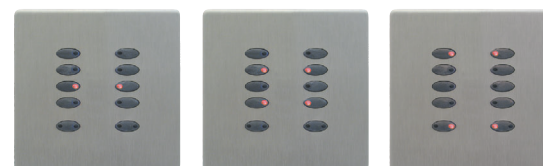

Plate LEDs flashing All Red LEDs Simultaneously Three Times In Quick Succession

This indicates that the plate has been "locked", and so button presses are not sent to the packs on the network.

To unlock a ten-button plate:

1. Hold down buttons 9 and 10 together (the bottom two buttons, which are slightly spaced away from the top buttons) for approx 5 seconds. They will flash red to indicate that they have been held for long enough.
2. Release buttons 9 and 10
3. Enter the unlocking code, as defined in the configuration. By default this is 1-2-3-4
4. The plate LEDs will flash green three times, to indicate that the plate has been unlocked.

A two button or five button plate can only be unlocked by using the software, or by removing the fascia plate to reveal the bottom-right button, and then following the procedure above.

Plate LEDs are Flashing 1-2-3-4-5-6-7-8-9-0 In Sequence

If the LEDs on the plates are flashing one at a time in sequence then it indicates that packs have not been addressed, and they are running one of the default factory-test sequences. You will also notice that the power channels on the packs are being switched on and off in a similar sequence. Set appropriate addresses on the packs, and then hold down the reset button for five seconds.

Checking a Plate Address and/or "Proof of Life"

In factory default settings the plate's LEDs will normally be blue. If no LEDs are illuminated on a plate, perhaps because the configuration file that has been loaded has extinguished them all, and yet you wish to confirm that there is power on the bus, follow the following procedure:

1. Hold down buttons 9 and 10 together (the bottom two buttons, which are slightly spaced away from the top buttons) for approx 5 seconds. They will flash red to indicate that they have been held for long enough.
2. Release the buttons and wait.
3. After about 5 seconds then plate will flash a blue LED three times. This indicates the plate address
4. A green LED will then flash three times. This indicates the plate's own firmware version number (NB this is not the same as the pack's firmware version).
5. Press any LED to exit diagnostic mode, and to return to the LED colours that were previously shown on the plate.



Each blue or green LED represents a digit, the first being the number of hundreds, the seconds being the number of tens and the third being the number of one's. So to indicate plate address one the blue LED will flash 0-0-1. To represent twenty seven the blue LED will flash 0-2-7. When flashing diagnostic numbers such as these, the plate buttons are renumbered slightly, values 1-5 are on the left, and 6-9 and 0 are on the right. This is different from the normal numbering scheme of the plate buttons.

How To Set The System Clock Using An LCD Plate

The clock is set automatically when a new configuration file is uploaded from a computer. It may also be set at any time using the Evolution Configuration Software. However it may also be set, without requiring a computer, using an LCD plate as follows:

1. Hold down bottom two buttons together for five seconds
2. A menu will appear; release the buttons

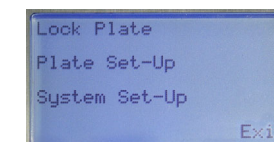

3. Press button three (system setup). A passcode entry screen appears, enter 2121.

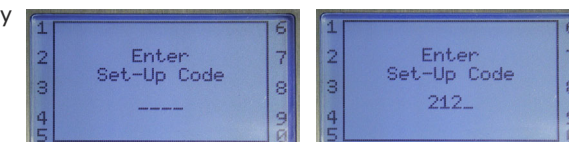

4. A new menu appears. Select programming options (button 1). A new menu appears

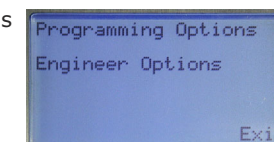

5. Select 'set the time' (button 3). The current time is shown in the centre of the screen, and may be adjusted using the controls on the screen.

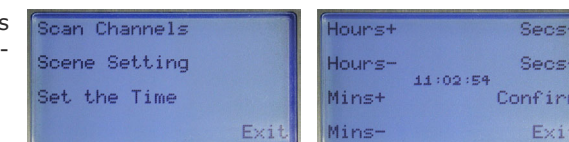

6. Select 'confirm' when the time has been adjusted correctly. NB the time displayed will not continue to update from the internal clock whilst you are doing this

7. Do the same thing for the date

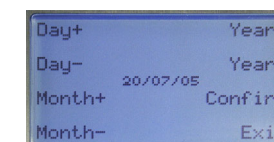

8. Press 'confirm' when date has been adjusted correctly

9. Press 'exit' (button 8) three times to leave the menus

Glossary of Terms

Configuration

A file that is loaded into all of the packs on a network to describe the particular configuration and system behaviour for a specific site or project. The configuration included all the lighting levels, and details of which buttons are used to control which outputs. Configuration files may have any name, but end with the file extension .evo.

Digital Board

The processor module at the right-hand end of the Evolution pack.

EVO-INT-232

A small silver box that converts M-Bus data to RS232, according to the configuration file.

Firmware

A file that is loaded into the packs to tell them how to "be an Evolution" system. Evo firmware files always have the name EvoFlash.Hex

M-Bus

The Evolution bus, with A, B, C and D terminals. This carries power and data to and from the control plates and other bus devices.

Pack

Evolution Power and Processor Unit. The "blue box" dimming system

Plate

Evolution plates have 2, 5 or 10 buttons with the option of an LCD display. The buttons' LEDs can be independently illuminated in any colour.

Triac

A power-electronic component for chopping the mains signal in order to dim lights.

Volt-Free Contact Inputs

A switch, where neither contact is connected to a voltage source. Volt free contacts may be used as inputs on either the plates or configurable-inputs on packs.