

EVOLUTION Power & Processor Unit EVO-10-12



- TWELVE CHANNELS of 10 amps resistive or 9 amps inductive loads, user selectable for dimming or switching.
- FULLY CONFIGURABLE control operation.
- MULTI-FUNCTION DSI, DMX, M-BUS, RS232, 0/1-10 Volt and contact operation.
- ASTRONOMICAL TIME CLOCK built in.
- INTELLIGENT SELF MONITORING power supply.
- SELF PROGRAM ON INSTALLATION facility for multi-unit applications.
- FACTORY SET DEFAULT operation for quick installation and testing.
- CIRCUIT PROTECTION individual 10 Amp Type C MCB for each channel.
- EMERGENCY OUTPUTS (2 per phase) fixed live MCB protected outputs for maintained emergency supplies.
- SUPPLY INPUT 200-250 Volt 50-60 Hz. Single or Three phase options.
- COMPLIES with EC EMC and Low Voltage Directives (CE).
- MODE products are guaranteed for two years.

EVOLUTION
IT WAS ONLY A MATTER OF TIME

TECHNICAL DATA

	EVO-10-12
Mains Supply	200-250 Volt 50-60 Hz. Single or Three phase options.
Control Fuse	20mm x 5mm 2 amp HRC Ceramic. (3)
Channel Outputs	12 x 10 amp resistive (9 amp inductive).
Circuit Protection	Individual 10 amp Type C Miniature Circuit Breaker.
Control Outputs	M-BUS, RS232, DMX, 0/1-10V, DSI.
Control Inputs	M-BUS, RS232, DMX, 0/1-10V, Contact Closure.
Contact Outputs	2 x SPCO (250VAC, 2A max) relay contacts.

	EVO-10-12
Standards	EMC Emissions EN55014, EMC Immunity EN61547, Voltage fluctuation EN61000-3-3, Safety EN60439-1 and EN60950
Conduit Entries	Base entry. Eight 32mm couplers or removable panel.
Dimensions	534 mm x 482 mm x 160 mm.
Fixing Centres	452 mm x 464 mm.
Weight	17 kgs.
Packed Size	600 mm x 550 mm x 250 mm.
Packed Weight	18 kgs.

DESCRIPTION

Evolution is a versatile and highly configurable architectural control system designed for both lighting and peripheral management. Evolution is uniquely adaptable, making it an ideal choice for use in a vast number of applications including modern smart homes, shopping centres, restaurants, hotels, cruise ships, boardrooms, hospitality suites and offices. System features include RS232, DMX, DSI and 0/1-10v controls. A built-in astronomical clock facilitates events triggered at any time of day, linked with sunrise - sunset calculations or by user definable seasons. Any input may control any output with the ability to provide operation of a sequence of events, for example, control of lighting, blind motors, commands to building management systems, colour changing etc. Unique features such as self-program-on-installation and distributed intelligence make the Evolution simple to install and maintain.

The Evolution power and processor unit builds on the quality and reliability of Mode product designs and offers high specification control and power management in a mechanically, electrically and thermo dynamically designed unit. All Mode products are guaranteed for a two year period.

EVO-10-12 INTERNAL DETAILS

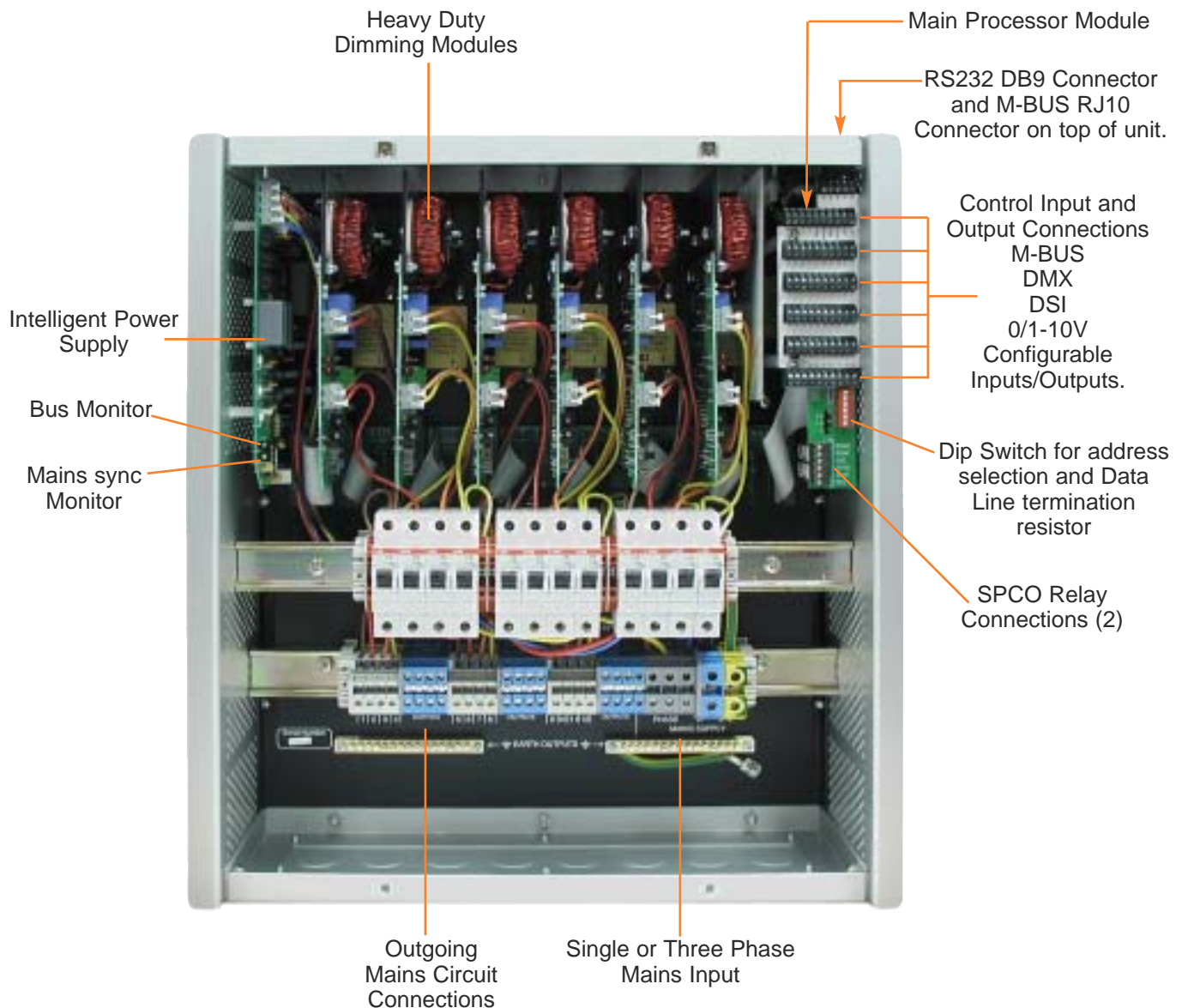

COMPANY SUMMARY

Mode was established in 1970 as an Original Equipment Manufacturer in Hertfordshire, England. Mode designs and manufactures electronic products principally for the lighting industry, initially supplying the discotheque market and more recently expanding into the architectural and cruise ship markets. Mode is a subsidiary of a privately owned Holding Company and has four associated electronic companies who together trade as "The Mode Group".