

www.edincontrols.com

The DIN-rail mounting modular lighting control solution from Mode Lighting.

CONTENTS:

- 4 x 3A Dimmer
- 300mm Data-Bus Link Cable

INSTALLATION GUIDE:

4 x 3A Dimmer Module DIN-03-04

The eDIN 8 x 2A Dimmer module is a 9M sized, leading edge dimmer suitable for inductive or resistive loads of up to 10A total.

MOUNTING

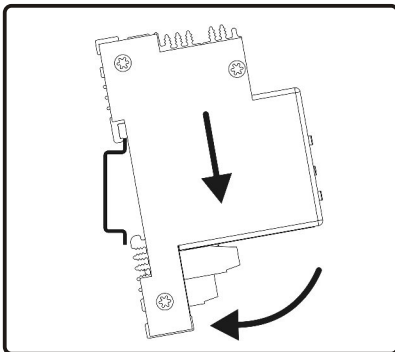
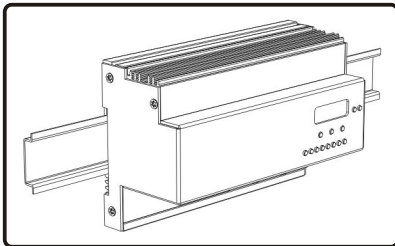

Modules must be installed within a suitable surface mount enclosure with integral DIN rail. Installation must be carried out by a qualified electrician in accordance with National Wiring Regulations and other applicable regulations. Compliance to EC EMC and Low Voltage Directives may be invalidated if not used or installed according to the published specification.

eDIN modules are designed to attach to a standard 35mm wide DIN rail (EN 50022, BS 5584). To install, simply hook the module from the top, push down and click into place (see diagram).

Dimmer modules produce heat according to loading. Care should be taken that the maximum ambient temperature of 40°C is not exceeded, particularly when installed within small non-ventilated enclosures or when multiple dimmer modules are installed within a single enclosure.

All eDIN modules must be earthed. Modules contain no user serviceable parts and should not be opened.

- Module Size:** 9M, L156mm x W100mm x H64mm
- Mains Input:** 230V +/- 10% 50/60Hz, single phase
- Power Input:** 24V, 50 mA max. from data bus
- Max. Wire Size:** 2.5mm² (input), 1.5mm² (output)
- Control Input:** Mode M-BUS
- M-BUS Connection:** 2 x RJ-45 (in and out)
- Loading:** 3A (approx. 700W) per channel resistive or inductive load. Total 10A max.
- ta Max:** 40°C
- tc Max:** 80°C
- Standards:** (CE EMC & LVD) EN55015, EN61547, EN61000-3-2, EN61000-3-3 & EN60669-2-1

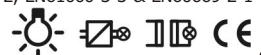

PROTECTION ON MAINS INPUT

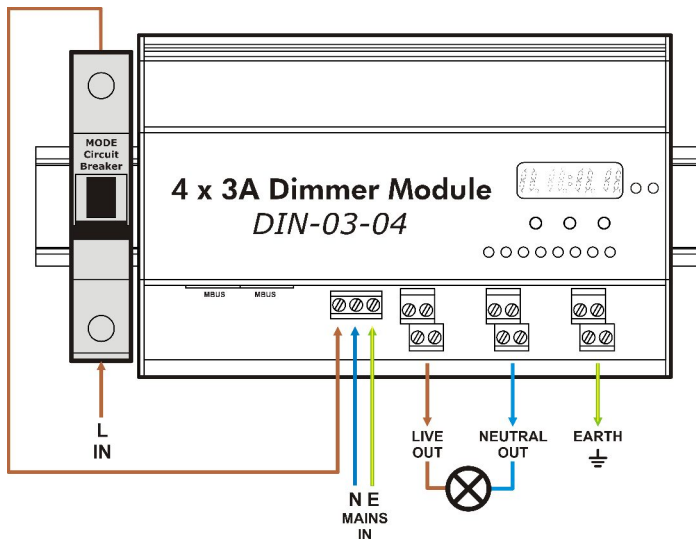

PROTECTION ON OUTPUT CIRCUITS

- Output circuits may be protected by suitably rated MCBs as shown if required.
- IMPORTANT:** Mains input must be protected by 10A maximum type C MCB.

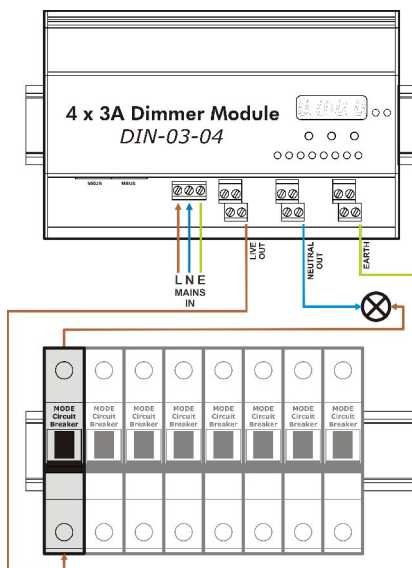
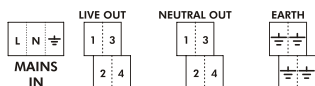

WIRING

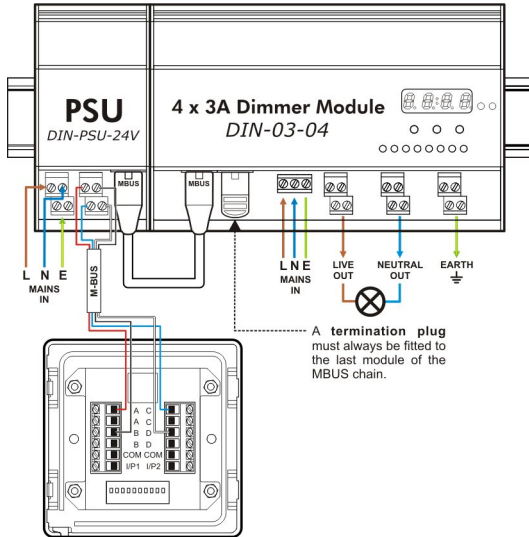

IMPORTANT:

- Correctly certified cables must be used for all mains voltage and extra low voltage MBUS connections in accordance with National Wiring Regulations and other applicable regulations.
- Mains input to power supply must be protected by a suitably rated MCB.
- Mains input to dimmer module must be protected by 10A maximum type C MCB.

- In order to test an eDIN system once it has been wired together, follow the highlighted instructions on the following page.

STANDALONE MODE PROGRAMMING

This is a set of instructions for programming scenes of up to 8 circuits using a 10-button single gang switch plate.

Note: The address of the plate must be set to the same address as the dimmer module.

To begin programming scenes:

1

Hold down the scene button (1-8) for **5 secs** for the scene that you wish to edit. The LED for the selected scene will now flash **blue** (channels that are included in the scene are illuminated **green** and excluded channels are illuminated **red**). The following four functions (A, B, C & D) can now be programmed in any order. These are **optional** features and if the settings are not edited then default functions are used.

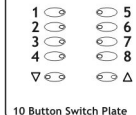

10 Button Switch Plate



A. Set Scene Levels

To change the **master brightness** of a complete scene, press the **Δ** or **▽** button to raise or lower **all** channels together.



B. Set Channel Levels

To set the **level** of a channel, press and hold the desired channel button (1-8) and hold **Δ** or **▽** to raise or lower the brightness level as required.

2



C. Set Scene Fade Time

To change the **fade time**, begin by pressing and holding the buttons 1 and 5 together for 2 seconds.

Buttons 1-4 will now be illuminated red with varying levels of brightness. The brightest button indicates the fastest fade time. Select a button:

Button 1 = 0 seconds **Button 3** = 4 seconds
Button 2 = 2 seconds **Button 4** = 8 seconds



D. Include / Exclude Channels

To **include / exclude** a channel, hold the required channel button (1-8) and then press **Δ** to **include** the channel or **▽** to **exclude** the channel.

Channels that are included in the scene will be illuminated green and channels that are excluded will be lit red. Channels which are excluded from a scene will not change brightness when the scene is selected.

3

To **exit** programming mode, hold down the flashing blue scene button for five seconds. Alternatively, to begin editing another scene, hold down the button for the new scene for five seconds and begin editing options A, B, C & D as above (return to stage two).

Other Plate Functions

Master Plate - Setting a plate's address to 511 sets it as a 'master' which will control all modules on any address.

On / Off Switch - There are two sets of contact input terminals on the rear of the plate. A contact closure on Input 1 has the same effect as pressing the **▽** button. A contact closure on Input 2 has the same effect as pressing the **Δ** button. These inputs could also be used on a plate set to address 511 to facilitate an 'all on' and an 'all off' function.

SETUP USING ONBOARD MENU

The on-board menu on all the eDIN modules is used to setup a device for use in **standalone** mode. Channel settings can be adjusted using this menu or by using a switch plate (as per earlier instructions). Alternatively, adding an eDIN Network Processor Unit to your setup will allow you to configure your system using eDIN software, operated using a web browser via an ethernet connection.

